

CONTACTS APPARENTS IP67  
SWITCHES IP67

TYPES: XCM-A110  
83 820 007

Ech: 1/3,125

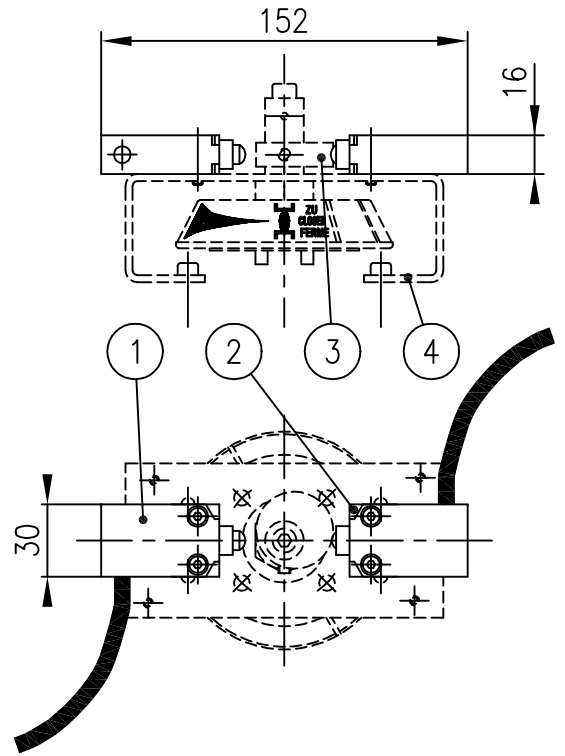
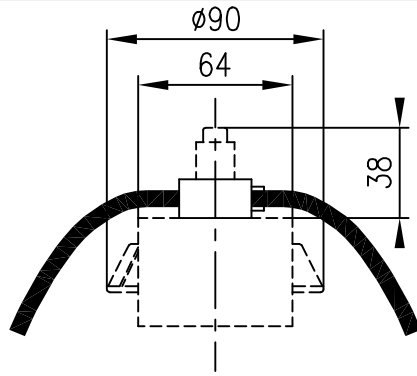

NOMENCLATURE / PART LIST:

REP.	Nb.	DESIGNATION
1	1	CONTACT (Standard: "O" -Ouverture-) SWITCH (Standard: "O" -Opening-)
2	1	CONTACT (Standard: "F" -Fermeture-) SWITCH (Standard: "C" -Closing-)
3	1	CAME / CAM
4	1	SUPPORT ACCESSOIRES ANCILLARY BRACKET

CARACTERISTIQUES GENERALES / GENERAL CHARACTERISTICS:

- FONCTION: INVERSEUR UNIPOLAIRE A ACTION BRUSQUE.  
FUNCTION: SPDT Changeover

TYPE	MARQUE	PROTECTION ENCLOSURE	TEMPERATURE	DUREE DE VIE LIFETIME	TENSION MAX. MAX. VOLTAGE	INTENSITE MAX. THERMAL RATING
XCM-A110	TELEMECANIQUE	IP 67	-25°C/+70°C	10 <sup>7</sup> OPERATIONS	500 VCA/VAC	6 A
83 820 007	CROUZET	IP 67	-25°C/+70°C	10 <sup>7</sup> OPERATIONS	500 VCA/VAC	11 A

SCHEMA DE RACCORDEMENT / WIRING DIAGRAM:

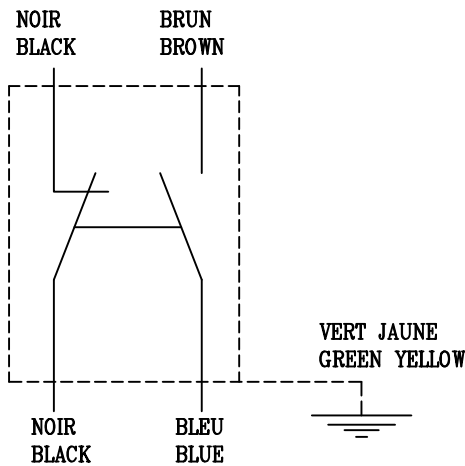

- RACCORDEMENT / CONNECTION:  
1 CABLE, 5 CONDUCTEURS / WIRES (0,75 mm<sup>2</sup>)  
LONGUEUR / LENGTH: 1 m

- ATTENTION / WARNING:  
Les circuits NO et NF doivent avoir la meme polarite.  
The NO and NC circuits must be used with the same polarity.

REV	DATE	A	06/88	B	01/89	C	06/89	D	01/93	E	06/95	F	09/97			
-----	------	---	-------	---	-------	---	-------	---	-------	---	-------	---	-------	--	--	--

**SAPAG**  
Robinetterie Industrielle

ACTIONNEUR PNEUMATIQUE  
PNEUMATIC ACTUATOR

151697

JUIN 88

D A D

Ce document est la propriété exclusive de SAPAG Robinetterie Industrielle, l'usage, la reproduction, la communication à des tiers de ce document doivent faire l'objet d'une autorisation écrite préalable de notre part. This document is the sole property of SAPAG Robinetterie Industrielle, it shall not, without the prior written permission of SAPAG Robinetterie Industrielle, be used, copied or disclosed to third parties.