

DIMENSIONS, CARACTERISTIQUES  
DIMENSIONS, CHARACTERISTICS

242-10M  
STANDARD

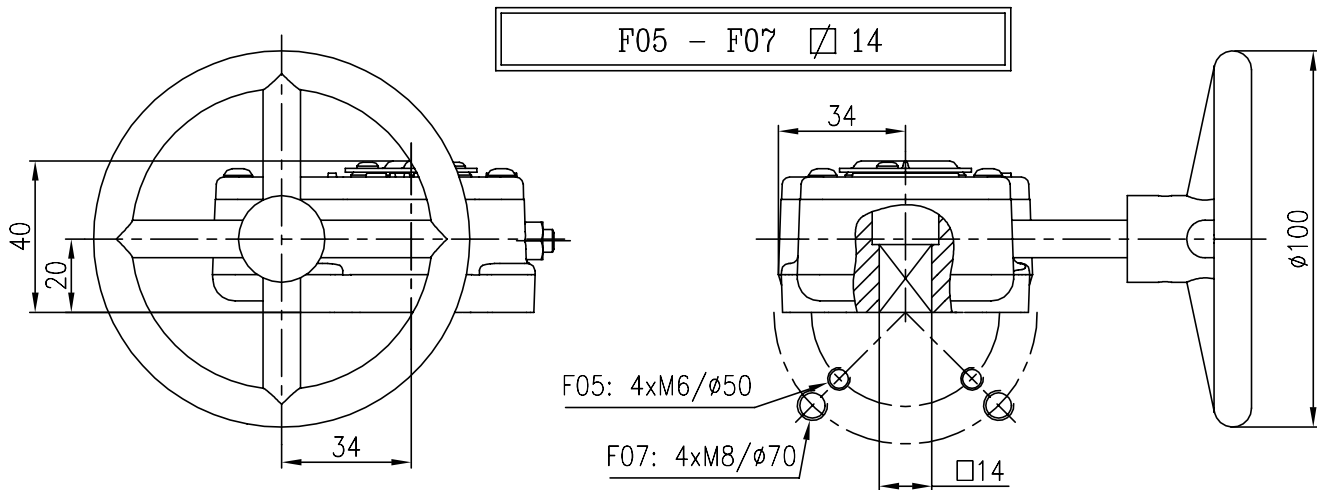

BUTEES MECANQUES REGLABLES 90 ±5°  
MECHANICAL ADJUSTABLE STOPS

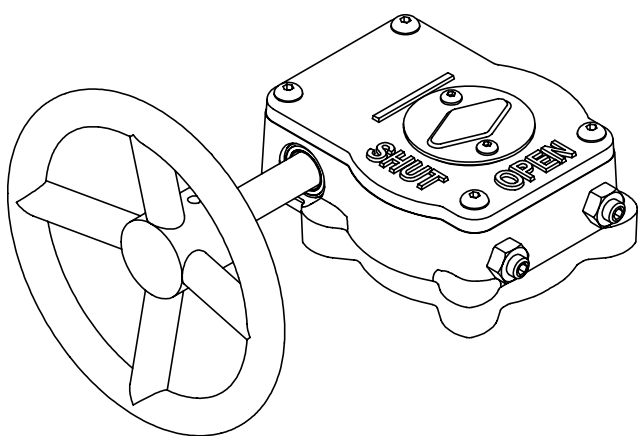

DIMENSIONS EN mm  
DIMENSIONS IN mm

- REDUCTEUR IRREVERSIBLE A ROUE ET VIS SANS FIN
- ENTRETIEN NUL
- FERMETURE SANS HORAIRE
- TEMPERATURE AMBIANTE : -40 °C / +120 °C
- POIDS : 1,3 kg
- EQUIPEMENT STANDARD :
  - o BUTEES MECANQUES DE FIN DE COURSE
  - o INDICATEUR DE POSITION MECANIQUE

- WORK GEAR BOX
- NO MAINTENANCE
- CLOCKWISE CLOSING
- AMBIENT TEMPERATURE : -40 °C / +120 °C
- WEIGHT : 1,3 kg
- PROVIDED AS STANDARD :
  - o MECHANICAL ADJUSTABLE STOP
  - o MECHANICAL POSITION INDICATOR

LES COTES ET MASSES SONT DONNEES A TITRE INDICATIF / DIMENSIONS AND WEIGHT ARE GIVEN AS GUIDE

CARACTERISTIQUES TECHNIQUES TECHNICAL CHARACTERISTICS			
COUPLE DE SORTIE MAXI MAXI. OUTPUT TORQUE ( N.m )	RAPPORT DE REDUCTION REDUCTION RATIO	RAPPORT DE COUPLE MECHANICAL ADVANTAGE	Nbre DE TOURS NB OF TURNS
165	1/40	10 ±10%	10

REV. DATE A 05/14



ACTIONNEUR MANUEL  
MANUAL ACTUATOR  
ROTORK 242 SERIE

159683

MAI 2014

D A D