

JMC

DN500 – DN800

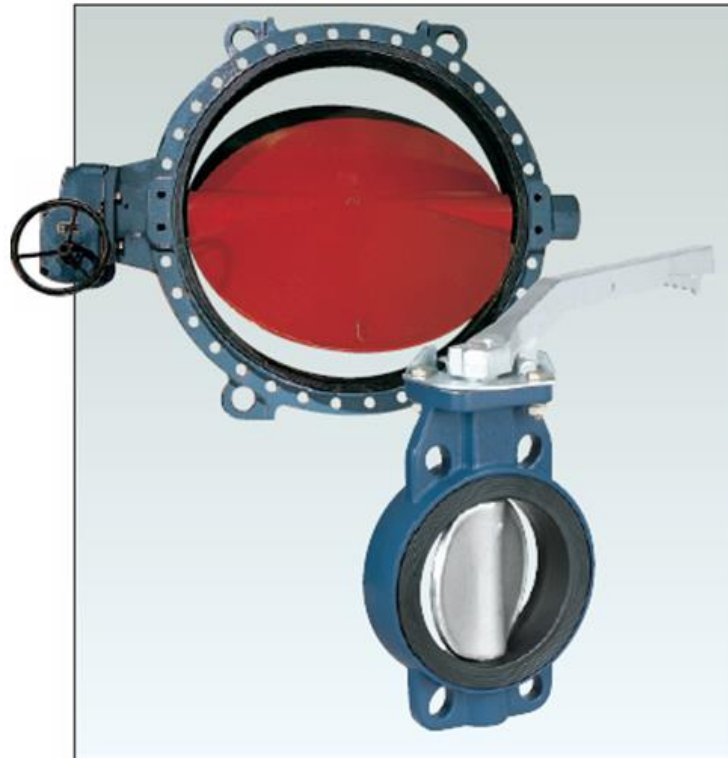



Rev / Date	A	01/17	B	05/26															
			ROBINET A PAPILLON BUTTERFLY VALVE											159787	1/25				
																	JANVIER 2017		

Table des matières

1.	Nomenclature / Part list	3
2.	Wafer - Dimensions	5
3.	LUG- Dimensions.....	6
4.	Double bride / <i>Double flange</i> - Dimensions	7
5.	Montage entre brides / <i>Assembly between flanges</i>	8
6.	Caractéristiques hydrauliques Kv / <i>Hydraulics characteristics Kv</i>	9
6.1.	Tableau des coefficients de débits / <i>Flow characteristics chart</i>	9
6.2.	Caractéristiques de débits intraséque / <i>Intrinsic flow characteristics</i>	9
6.3.	Formules simplifiées / <i>Simplified formula</i>	10
7.	Courbe pression température des matériaux	11
7.1.	Pression maximale de conception des corps / <i>Maximal body design pressure</i>	11
7.2.	Manchette / <i>Seat</i>	11
7.3.	Disque revêtu / <i>Coated disc</i>	13
8.	Etanchéité / <i>Tightness</i> 13	
8.1.	<i>Essai de fin de production / Production Control test</i>	13
8.2.	Tenue au vide / <i>Vacuum limits (FT159615)</i>	13
9.	Couple / <i>Torque(FT159615)</i>	14
9.1.	Couple de manœuvre / <i>Operating torque⁽²⁾</i>	14
9.2.	Couple maximum admissible / <i>maximum operating torque (159773)</i>	14
10.	Montage entre bride / <i>Assembly between flanges</i>	15
10.1.	Wafer – Visserie / <i>Bolting</i>	15
10.2.	WAFER : Compatibilité de raccordement / <i>Flange drilling compatibility</i>	16
10.3.	Lug – Visserie / <i>Bolting</i>	17
10.4.	LUG : Compatibilité de raccordement / <i>Flange drilling compatibility</i>	19
10.5.	Couple de serrage / <i>Tightening torque</i>	19
11.	Installation / <i>Assembly</i>	20
11.1.	Vitesse fluide / <i>Fluid speed</i>	20
11.2.	Installation / <i>Assembly</i>	20
11.3.	Orientation ligne d'arbre / <i>Shaft orientation</i>	20
11.4.	Instruction de montage / <i>Assembly instruction</i>	21
11.5.	Cotes des brides / <i>Flanges dimensions</i>	22
11.5.1.	Généralité / <i>General information</i>	23
11.5.2.	Cas des vannes Wafer / <i>Wafer valves case</i>	23
12.	Démontage ou montage tuyauterie amont ou aval / <i>Dismantling - mounting pipe</i>	24
13.	Conditions de stockage / <i>Storage conditions</i>	25

Rev / Date	A	01/17	B	05/26														
			<p align="center">ROBINET A PAPILLON</p> <p align="center">BUTTERFLY VALVE</p>										159787	2/25				
<p align="right">JANVIER 2017</p>																		

1. Nomenclature / Part list

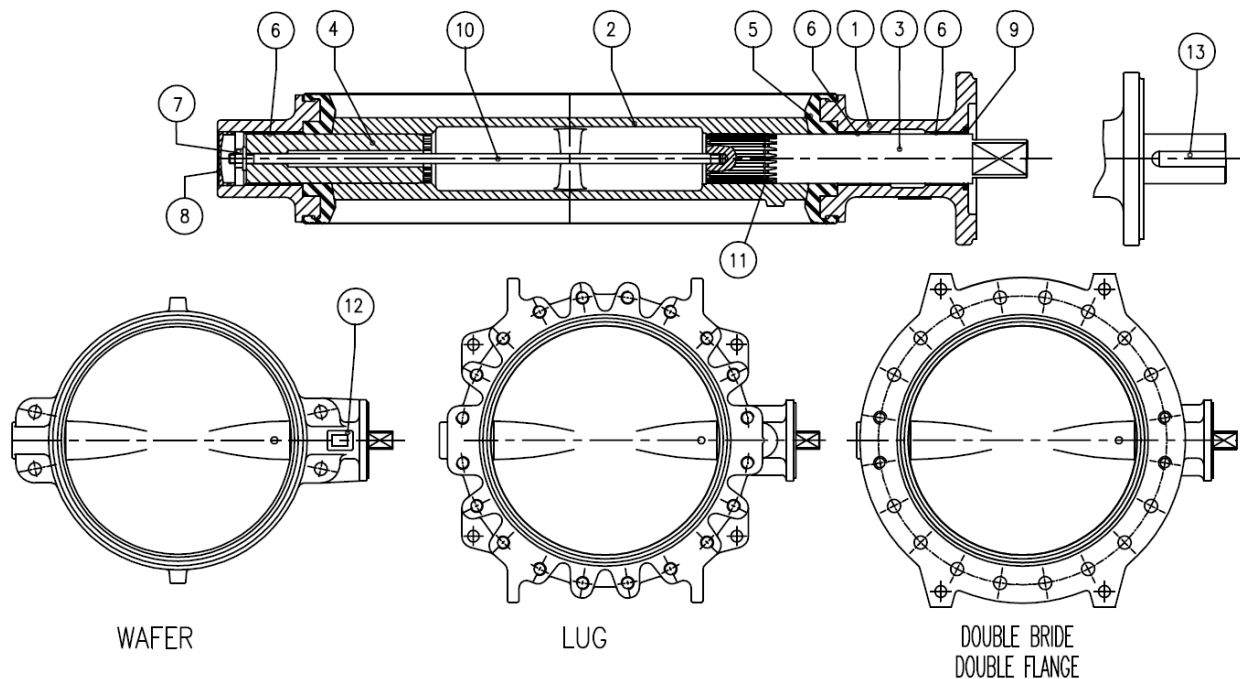

Rep Item	Nb Qty	Designation		MATIERE / MATERIALS ⁽¹⁾			Revetement Coating															
1	1	CORPS	BODY	Fonte GS / Ductile iron	EN-JS1020 (GJS400-18)	A536 Gd60.40.18	Epoxy															
				Acier carbone Carbon steel	1.0619	A216 WCB	Epoxy															
				Acier inoxydable / Stainless steel	1.4408	A351 CF8M																
				NiAlBz	CC333G	B148 C95800																
2	1	PAPILLON	DISC	Fonte GS / Ductile iron	EN-JS1030 (GJS400-15)		Epoxy ⁽³⁾															
				Acier inoxydable / Stainless steel	1.4409	A351 CF3M																
				NiAlBz	CC333G	B148 C95800																
3 + 4	1	ARBRE	SHAFT	Acier inoxydable / Stainless steel	1.4021	A276 Gd420																
	1	AXE	SPINDLE	Acier inoxydable / Stainless steel	1.4542	A564 Gd630																
5 ⁽²⁾	1	MANCHETTE	SEAT	Elastomère / Elastomeric	<table border="1"> <tr> <td>EPDM-Px</td> <td>✓</td> <td>NBR</td> <td>✓</td> <td>X-NBR</td> <td>✓⁽⁴⁾</td> <td>CSM</td> <td>✓⁽⁴⁾</td> </tr> <tr> <td>EPDM-S</td> <td>✓</td> <td>FKM</td> <td>✓</td> <td>H-NBR</td> <td>✓⁽⁴⁾</td> <td></td> <td></td> </tr> </table>	EPDM-Px	✓	NBR	✓	X-NBR	✓ ⁽⁴⁾	CSM	✓ ⁽⁴⁾	EPDM-S	✓	FKM	✓	H-NBR	✓ ⁽⁴⁾			
EPDM-Px	✓	NBR	✓	X-NBR	✓ ⁽⁴⁾	CSM	✓ ⁽⁴⁾															
EPDM-S	✓	FKM	✓	H-NBR	✓ ⁽⁴⁾																	
6	3	PALIER	BEARING	Acier carbone Carbon steel			PTFE															
7	1	ECROU	NUT	Acier carbone Carbon steel	+ Polyamide		Zinc															
8 ⁽²⁾	1	BOUCHON	PLUG	Plastic	Polyethylene																	
9 ⁽²⁾	1	JOINT V-RING	CHEVRON SEAL	Elastomère / Elastomeric	Nitrile																	
10	1	TIRANT	THRU-BOLT	Acier carbone Carbon steel			Zinc															
11	1	MANCHON	COUPLING	Acier inoxydable / Stainless steel	1.4021	A276 Gd420																
12	1	PLAQUE CONSTRUCTEUR	MANUFACTURING PLATE	Acier inoxydable / Stainless steel																		

Rev / Date

A

01/17

B

05/26



ROBINET A PAPILLON
BUTTERFLY VALVE

159787

3/25

JANVIER 2017

Heavy duty resilient seated butterfly

DN500 /DN800

13	1	CLAVETTE	KEY	Acier carbone Carbon steel			
----	---	----------	-----	-------------------------------	--	--	--

⁽¹⁾ Autres sur demande / *Others on request*

⁽²⁾ Pièce de rechange / *Spare parts*

⁽³⁾ Autres revêtements / *Others coatings* : Ebonite, Rilsan, Halar

⁽⁴⁾ Disponible jusqu'au DN600 / *Available still DN600.*

Rev / Date	A	01/17	B	05/26											
			<p align="center">ROBINET A PAPILLON BUTTERFLY VALVE</p>									159787	4/25		
												JANVIER 2017			

Heavy duty resilient seated butterfly

DN500 /DN800

2. Wafer - Dimensions

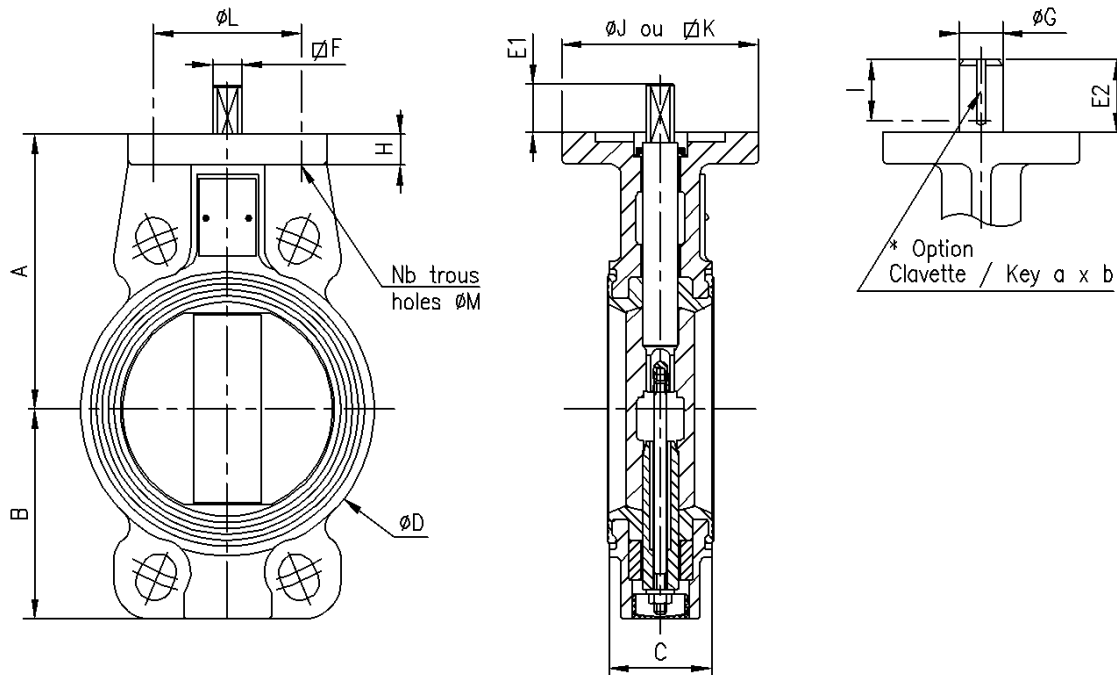

DN	A	B	C	ØD	Carré Square		ØG	Clavette* Key			BRIDE DE MOTORISATION TOP FLANGE				ISO5211 ISO5210		Masse** Weight Kg	
					E1	F		E2	a	b	l	H	J	K	L	Nb		M
500	425	406	127	571	63	46	60	85	18	11	80	25	210	-	165	4	22	107
550	467	442	154	630	63	46	60	85	18	11	80	25	210	-	165	4	22	135
600	495	461	154	670	63	46	60	85	18	11	80	25	210	-	165	4	22	145
650	548	527	165	738	81	55	80	108	22	14	100	30	300	-	254	8	18	195
700	570	550	165	776	81	55	80	108	22	14	100	30	300	-	254	8	18	217
750	610	580	165	843	81	55	80	108	22	14	100	30	300	-	254	8	18	275
800	640	600	190	882	81	55	80	108	22	14	100	30	300	-	254	8	18	310

Dimension [mm], masse [kg] sont données à titre indicatif seulement
 Dimension [mm], masse [kg] are given as a guide only

* Option

** Valeur pour un corps en fonte / papillon fonte.

Value are given for ductile iron body / ductile iron disc

Rev / Date	A	01/17	B	05/26														
													ROBINET A PAPILLON BUTTERFLY VALVE				159787	5/25
JANVIER 2017																		

3. LUG- Dimensions

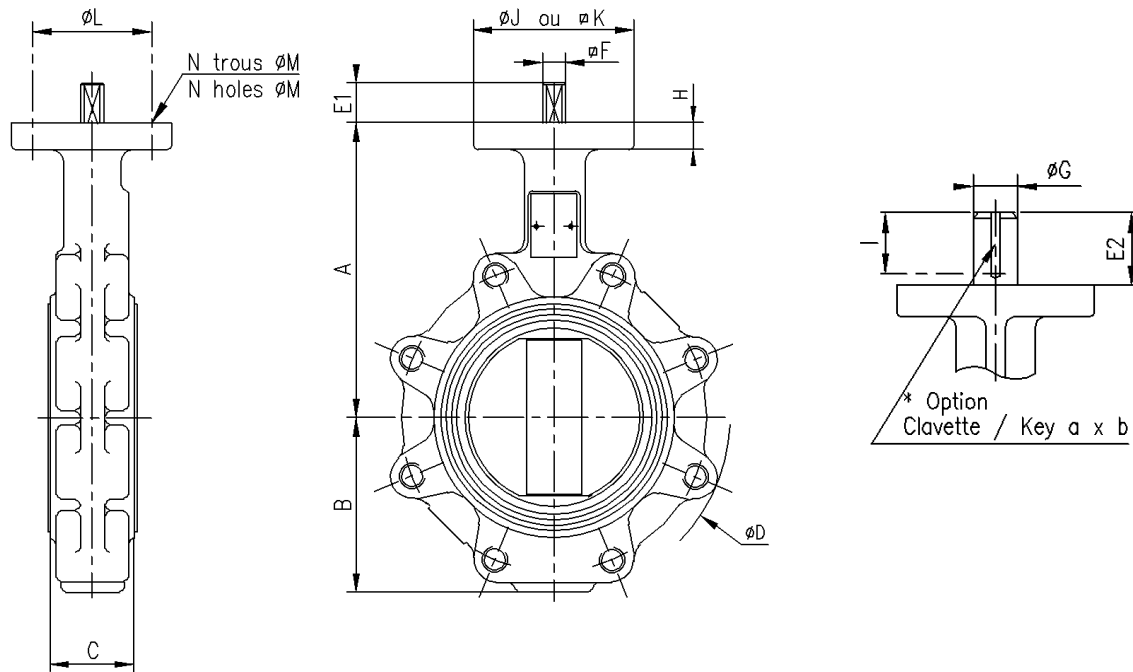

DN	A	B	C	ϕD	Carré Square		Clavette* Key					BRIDE DE MOTORISATION TOP FLANGE				ISO5211 ISO5210		Masse** Weight
					E1	F	ϕG	E2	a	b	l	H	J	K	L	Nb	M	Kg
500	425	406	127	720	63	46	60	85	18	11	80	25	210	-	165	4	22	180
550	467	442	154	720	63	46	60	85	18	11	80	25	210	-	165	4	22	230
600	495	461	154	828	63	46	60	85	18	11	80	25	210	-	165	4	22	270
650	548	527	165	884	81	55	80	108	22	14	100	30	300	-	254	8	18	275
700	570	550	165	945	81	55	80	108	22	14	100	30	300	-	254	8	18	280
750	610	580	165	970	81	55	80	108	22	14	100	30	300	-	254	8	18	370
800	640	600	190	1070	81	55	80	108	22	14	100	30	300	-	254	8	18	400

Dimension [mm], masse [kg] sont données à titre indicatif seulement
Dimension [mm], masse [kg] are given as a guide only

* Option

** Valeur pour un corps en fonte / papillon fonte.

Value are given for ductile iron body / ductile iron disc

Rev / Date	A	01/17	B	05/26																
															ROBINET A PAPILLON BUTTERFLY VALVE				159787	6/25
															JANVIER 2017					

Heavy duty resilient seated butterfly

DN500 / DN800

4. Double bride / Double flange - Dimensions

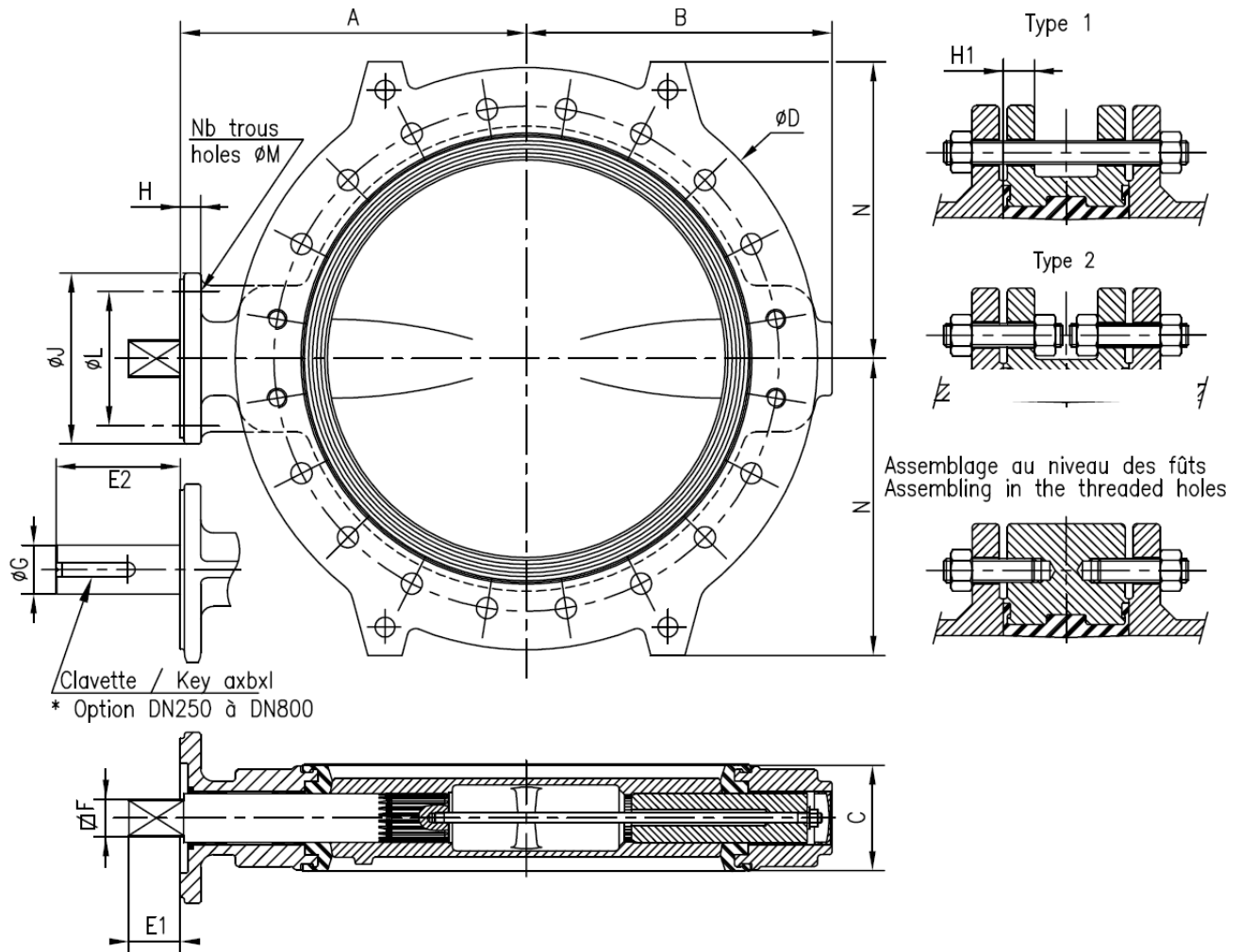

DN	A	B	C	ØD	Carré Square		ØG	E2	Clavette* Key			BRIDE DE MOTORISATION TOP FLANGE				Nb	M	Masse** Weight
					E1	F			a	b	l	H	J	K	L			
500	425	406	127	730	63	46	60	85	18	11	80	25	210	-	165	4	22	167
550	467	442	154	750	63	46	60	85	18	11	80	25	210	-	165	4	22	182
600	495	461	154	845	63	46	60	85	18	11	80	25	210	-	165	4	22	203
650	548	527	165	884	81	55	80	108	22	14	100	30	300	-	254	8	18	243
700	570	550	165	940	81	55	80	108	22	14	100	30	300	-	254	8	18	292
750	610	580	165	984	81	55	80	108	22	14	100	30	300	-	254	8	18	400
800	640	600	190	1060	81	55	80	108	22	14	100	30	300	-	254	8	18	403

Dimension [mm], masse [kg] sont données à titre indicatif seulement
Dimension [mm], masse [kg] are given as a guide only

* Option

** Valeur pour un corps en fonte / papillon fonte.

Value are given for ductile iron body / ductile iron disc

Rev / Date	A	01/17	B	05/26																
															ROBINET A PAPILLON BUTTERFLY VALVE				159787	7/25
															JANVIER 2017					

5. Montage entre brides / Assembly between flanges

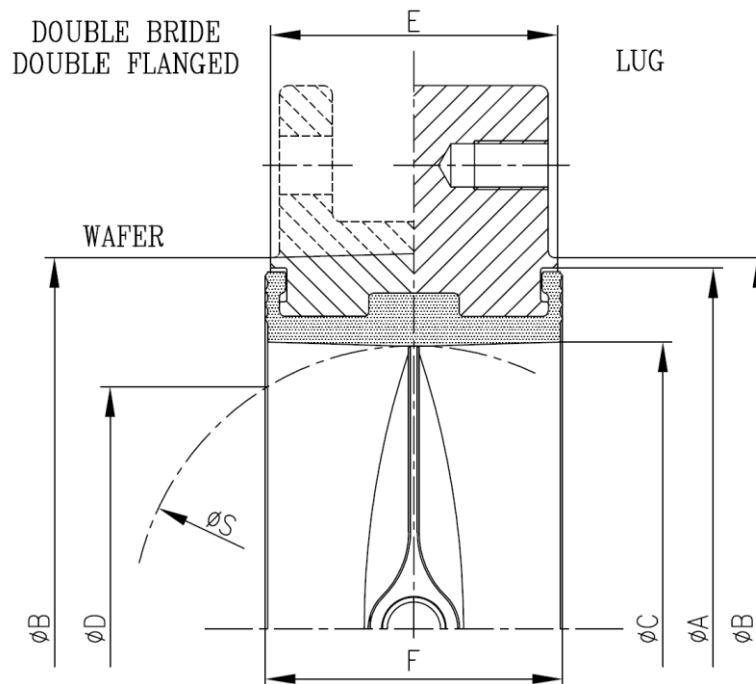

DN	ØA	ØB	ØC	ØD	E	F	ØS
500	554	547	488	469	127	132	485
550	606	626	540	516	154	159	540
600	653	670	589	564	154	159	585
650	713	733	640	615	165	170	634
700	758	776	687	658	165	170	678
750	814	832	742	815	165	170	734
800	863	882	784	745	190	196	773

Dimensions [mm], masse [kg] sont données à titre indicatif seulement.
 Dimensions [mm], masse [kg] are given as a guide only.

Rev / Date	A	01/17	B	05/26													
			<p align="center">ROBINET A PAPILLON BUTTERFLY VALVE</p>										159787	8/25			
													JANVIER 2017				

6. Caractéristiques hydrauliques Kv / Hydraulics characteristics Kv

6.1. Tableau des coefficients de débits / Flow characteristics chart

DN	20°	30°	40°	50°	60°	70°	80°	90°
500	566	1131	1881	3395	5280	9997	17160	18800
550								
600	828	1656	2750	4969	7730	14630	25124	27600
650								
700	1161	2323	3850	6969	10813	20515	35233	38600
750	1358	2715	4538	8168	12703	24049	41290	45400
800	1540	3080	5148	9266	14410	27280	46838	51500

6.2. Caractéristiques de débits intrasèque / Intrinsic flow characteristics

Le débit intrasèque est inscrit dans la zone hachurée suivante :

Intrinsic flow characteristics are included in below hachured area :

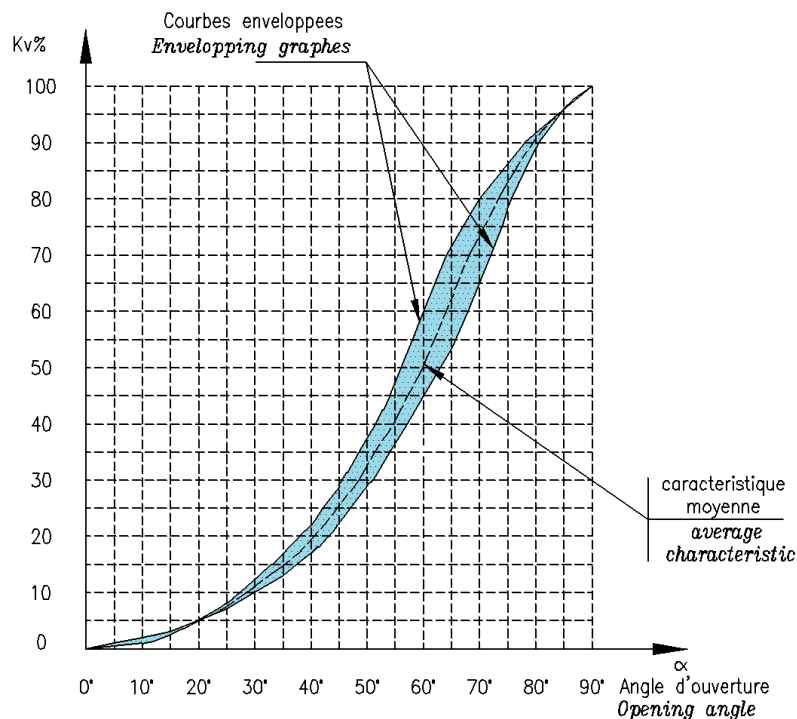

Rev / Date	A	01/17	B	05/26										
			<p align="center">ROBINET A PAPILLON BUTTERFLY VALVE</p>								159787	9/25		
											<p align="center">JANVIER 2017</p>			

6.3. Formules simplifiées / Simplified formula

Elles permettent de calculer la perte de charge du robinet en fonction des conditions d'écoulement, ou de définir le dimensionnement du robinet (réglage) entre 20° et 70°

They make it possible to calculate the pressure drop of the valve according to the flow conditions, or to define the dimensioning of the valve (setting) between 20 ° and 70 °

Perte de charge		Fluides incompressibles	Gaz
<i>Headloss</i>		<i>Incompressible fluids</i>	<i>Gas</i>
$\Delta P < \frac{P_1}{2}$ $P_2 > \frac{P_1}{2}$ $\Delta P > \frac{P_1}{2}$ $P_2 < \frac{P_1}{2}$	K_v	$= \frac{Q}{31,6} \sqrt{\frac{\rho_1}{\Delta P}}$	$= \frac{Q}{514} \sqrt{\frac{\rho_{N.T}}{\Delta P \cdot P_2}}$ $= \frac{2 \cdot Q_N}{514 \cdot P_1} \sqrt{\rho_{N.T}}$

Kv		Coefficient de débit	Flow coefficient
Q	m3/h	Débit	Flow rate
ΔP	Bar	Perte de charge	Headloss
P1	Bara	Pression amont absolue	Absolute upstream pressure
P2	Bara	Pression aval	Absolute downstream pressure
Q	m3/h	Débit normal (0° / 1 atm)	Normal flow rate (0° / 1 atm)
T	°K	Temperature absolue	Absolute temperature
	Kg/m3	Masse volumique	Volumic weight
	Kg/m3	Masse volumique normal (0° / 1 atm)	Normal volumic weight (0° / 1 atm)

Ces formules peuvent être utilisées uniquement lorsque le diamètre de la vanne est égal au diamètre de la conduite.

These formulas can be used only when valve diameter is the same as pipe diameter.

Rev / Date	A	01/17	B	05/26												
												ROBINET A PAPILLON BUTTERFLY VALVE			159787	10/25
															JANVIER 2017	

7. Courbe pression température des matériaux

7.1. Pression maximale de conception des corps / Maximal body design pressure

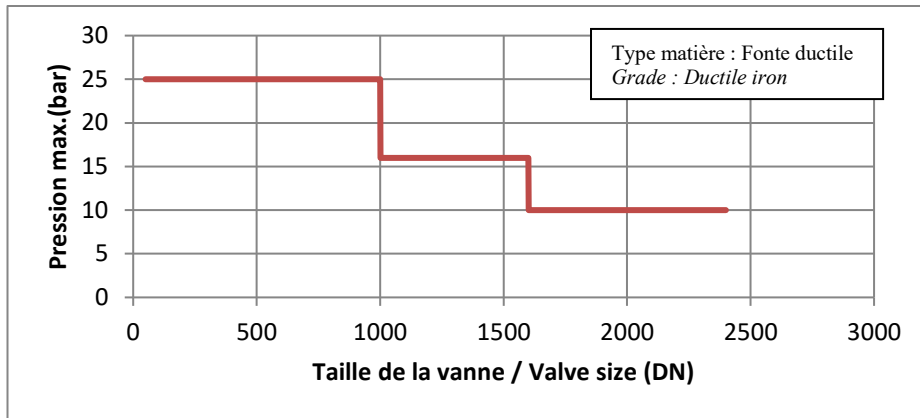

7.2. Manchette / Seat

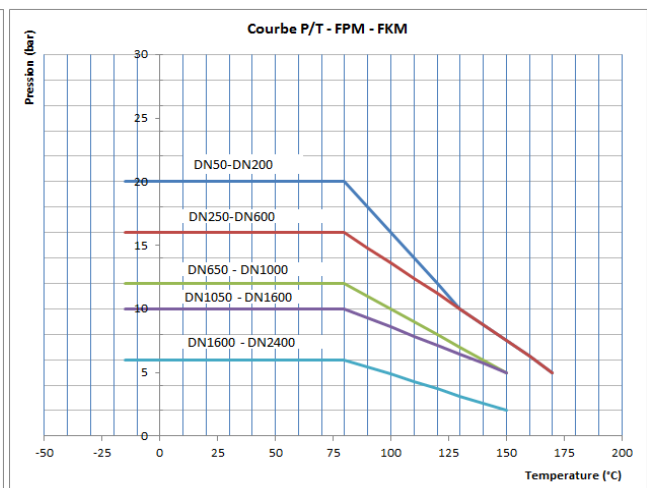
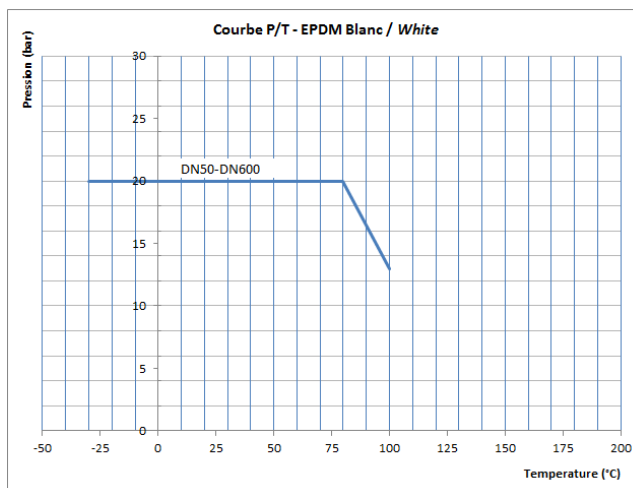
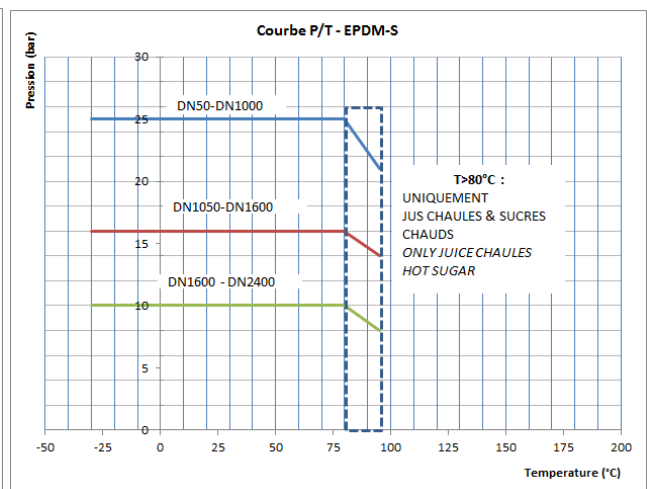
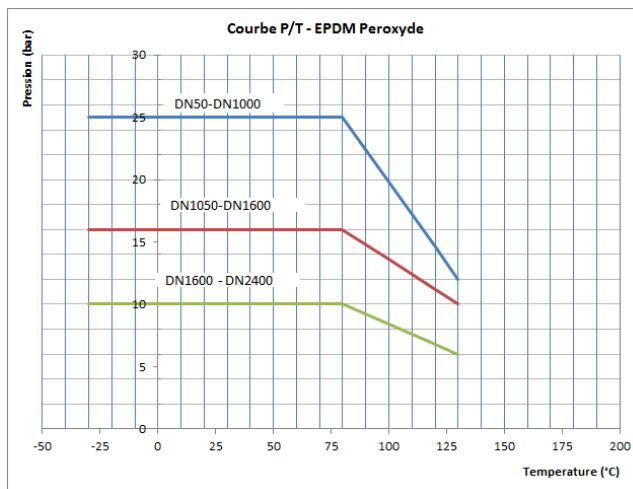

Rev / Date	A	01/17	B	05/26										
		ROBINET A PAPILLON BUTTERFLY VALVE									159787 11/25 JANVIER 2017			

Heavy duty resilient seated butterfly

DN500 /DN800

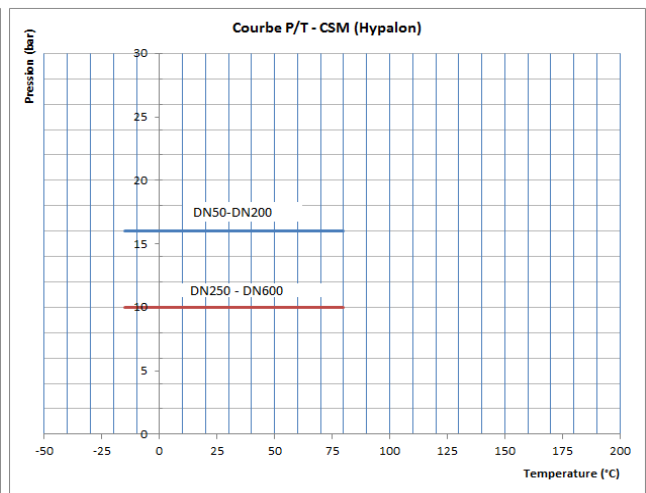
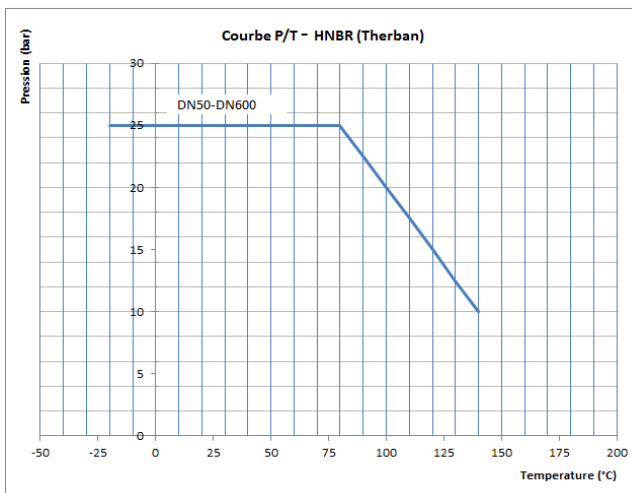
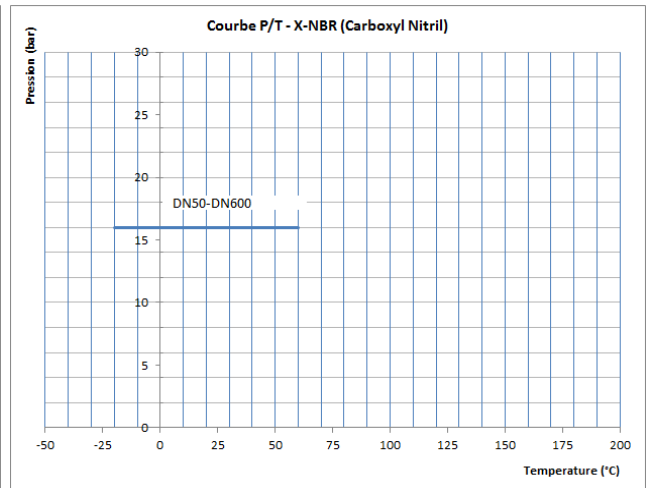
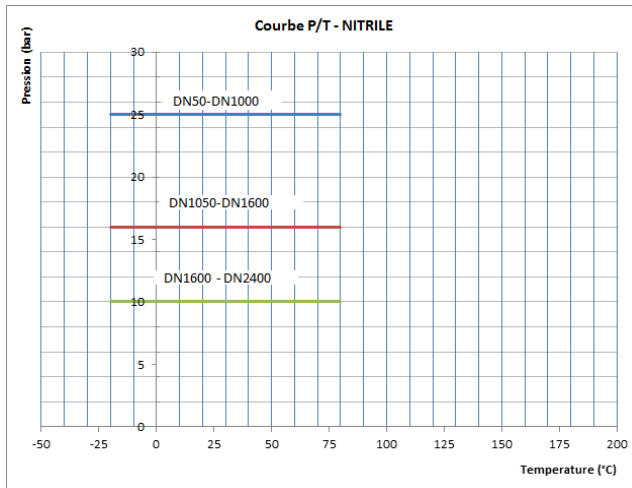

Rev / Date	A	01/17	B	05/26										
		<p align="center">ROBINET A PAPILLON BUTTERFLY VALVE</p>									<p align="right">159787 12/25 JANVIER 2017</p>			

7.3. Disque revêtu / Coated disc

		DN		Temperature		Epaisseur Thickness (μ m)	Pmax	F.T. / D.S.
		De/ From	A / to	Min.	Max			
Fonte ductile revetu EPOXY	<i>Ductile iron EPOXY coated</i>	50	2400	-10°C ⁽¹⁾	+80°C	80		154451
Fonte ductile revetu RILSAN	<i>Ductile iron RILSAN coated</i>	50	2400	-10°C ⁽¹⁾	+80°C ⁽²⁾	80		154450
Fonte ductile revetu HALAR	<i>Ductile iron HALAR coated</i>	50	2400	-10°C ⁽¹⁾	+80°C	600		159541
Fonte ductile revetu EBONITE	<i>Ductile iron EBONITE coated</i>	50	300	-5°C	+80°C	3000		159509
		350	450	+5°C	+95°C			
		500	2400			4000		
Fonte ductile revetu Caoutchouc ⁽³⁾	<i>Ductile iron Rubber coated</i>	350	600	-10°C ⁽¹⁾	+60°C		10 bar	159541

⁽¹⁾ Limitation due à la fonte ductile FGS 400-15 / Restriction due to ductile iron FGS 400-15

⁽²⁾ Pic de température / Temperature peaks : 110°C

8. Etanchéité / Tightness

8.1. Essai de fin de production / Production Control test.

La JMC est un robinet bidirectionnel sans sens préférentielle d'écoulement.

The JMC is a bidirectional valve without preferential flow direction.

L'étanchéité du siège est :

Seat tightness is :

EN12266-1 – Taux A

EN12266-1 – Rate A

8.2. Tenue au vide / Vacuum limits (FT159615)

DN	Construction / Design	Pression minimale / Minimal pressure	Pression maximale / Maximal pressure	Type de manchette / Seat material
50 - 600	Standard	1,33 10 ⁻³ bar(a) 1 torr(a)	10 bar(g)	EPDM NBR
	Collé / Glued	1,33 10 ⁻⁵ bar(a) 10 ⁻² torr(a)	6 bar(g)	EPDM NBR

Rev / Date	A	01/17	B	05/26												
											ROBINET A PAPILLON BUTTERFLY VALVE			159787	13/25	JANVIER 2017

9. Couple / Torque(FT159615)

9.1. Couple de manœuvre / Operating torque⁽²⁾

DN	Nominal	CN/2 ⁽¹⁾
500	2300	1530
550		
600	3200	2130
650		
700	4500	3000
750	5200	3800
800	6000	4000

⁽¹⁾ Construction couple réduit / *Reduced torque version 6 bar max (Manchette / Seat EPDM ou/or NBR)*

⁽²⁾ Pour les papillons revêtus Ebonite ou Caoutchouc, prévoir ajouter 30% aux valeurs ci-dessus. For Ebonite or rubber coated disc, add 30% to above value

9.2. Couple maximum admissible / maximum operating torque (159773)

DN	Embase	Couple max Embase ISO5211 ⁽¹⁾	Connection ⁽²⁾	Couple max Connection ISO5211	Couple de rupture Breaking torque	
					1.4021 / A216 Gd420 2.4375 (~K500)	1.4542 / A564 Gd630
500	F16	4000 N.m	SQ46 V60	4000 N.m	14335 N.m	16011 N.m
550						
600						
650						
700	F25	8000 N.m	SQ55 V80	12000 N.m	23753 N.m	26530 N.m
750						
800						

⁽¹⁾ Boulons sollicités en traction à 290 MPa et coefficient de frottement de 0,2 / *Bolts in tension only with a stress of 290 MPa and a coefficient of friction of 0.2.*

⁽²⁾ L : Entraînement par carré parallèle / *Parallel square head drive*
 H : Entraînement par méplat / *Flat head drive*
 V : Entraînement par clavette / *Single key drive*

Rev / Date	A	01/17	B	05/26											
												ROBINET A PAPILLON BUTTERFLY VALVE		159787	14/25
														JANVIER 2017	

10. Montage entre bride / Assembly between flanges

PN6, PN10, PN16, PN25 :

Visserie pour bride en fonte ductile suivant EN1092-2 / ISO7005-2
Bolts for Ductile iron flanges according to EN1092-2 / ISO7005-2

PN20, CI150

Visserie pour bride en fonte ductile suivant ISO7005-1, ASME B16.5, ASME B16.47 Serie A
Bolts for Ductile iron flanges according to ISO7005-1, ASME B16.5, ASME B16.47 Serie A

10.1. Wafer – Visserie / Bolting

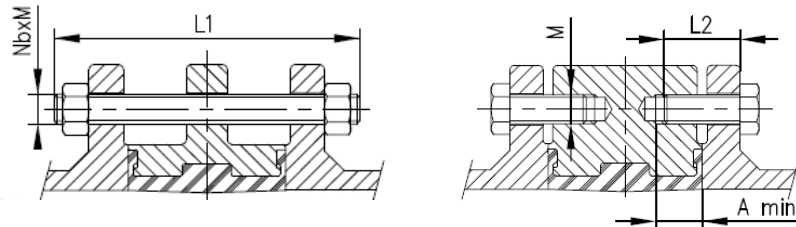

	ISO7005-1 EN1092-1&2					ISO7005-1 EN1092-1&2					ISO7005-1 EN1092-1&2					ISO7005-1 EN1092-1&2				
	PN6					PN10					PN16					PN25				
	Nb	M	L1	Nb	L2	Nb	M	L1	Nb	L2	Nb	M	L1	Nb	L2	Nb	M	L1	Nb	L2
500	20	M20	235			20	M24	235			20	M30	260			20	M33	275		
550																				
600	20	M24	270			20	M27	275			20	M33	300			20	M36	315		
650																				
700	20+	M24	285	2 x 4	80	20+	M27	290	2 x 4	80	20+	M33	310	2 x 4	90	20+	M39	345	2 x 4	90
750																				
800	20+	M27	320	2 x 4	100	20+	M30	325	2 x 4	100	20+	M36	355	2 x 4		20+	M45	390	2 x 4	110

	ISO7005-1 EN1759					ASME B16.5 / B16.42 ASME B16.47 Serie A				
	PN20/CI150					CI150				
	Nb	M	L1	Nb	L2	Nb	M	L1	Nb	L2
500	20	M30	280			20	1"1/8	235		
550										
600	20	M33	325			20	1"1/4	275		
650										
700	24+	M33	385	2 x 4	120	24+	1"1/4	385	2 x 4	120
750	24+	M33	390	2 x 4	120	24+	1"1/4	390	2 x 4	120
800	24+	M39	440	2 x 4	140	24+	1"1/2	440	2 x 4	140

Rev / Date	A	01/17	B	05/26																	
															ROBINET A PAPILLON BUTTERFLY VALVE					159787 15/25 JANVIER 2017	

Heavy duty resilient seated butterfly

DN500 /DN800

10.2. WAFER : Compatibilité de raccordement / Flange drilling compatibility

		DN	500	550	600	650	700 ⁽¹⁾	750 ⁽¹⁾	800 ⁽¹⁾
		Size	20"	22"	24"	26"	28"	30"	32"
ISO 7005 / EN 1092	PN6	*			*				
	PN10				*				
	PN16				*				
	PN20				*				
	PN25				*				
CLASS 125 / CLASS 150	ASME B16.1				*				
	ASME B16.5				*				
	ASME B16.42				*				
	ASME B16.47 A				*				
	MSS SP-44				*				
	API 605				*		X	X	X
AWWA C207	Table 2-3-4-5				*				
CLASS 300	ASME B16.5	X		X					
	ASME B16.42								
	ASME B16.47 A					X	X	X	
	MSS SP-44	X		X		X	X	X	
	API 605								
BS10	TABLE A	X		X					
	TABLE D								
	TABLE E								
JIS B2210	5K	*			*				
	10K			X					
	16K	*		X			X		
	20K			X		X	X	X	

	Raccordement possible	Flange drilling possible
X	Raccordement impossible	Flange drilling impossible
	Raccordement non défini par la norme	Flange drilling not defined by standard
*	Contrebride requise pour montage en bout de conduite	Counterflange requested for end of line assembly
(1)	4 trous taraudés par face	4 threaded holes per face.

Rev / Date	A	01/17	B	05/26										
		ROBINET A PAPILLON BUTTERFLY VALVE										159787	16/25	
												JANVIER 2017		

Heavy duty resilient seated butterfly

DN500 /DN800

10.3. Lug – Visserie / Bolting

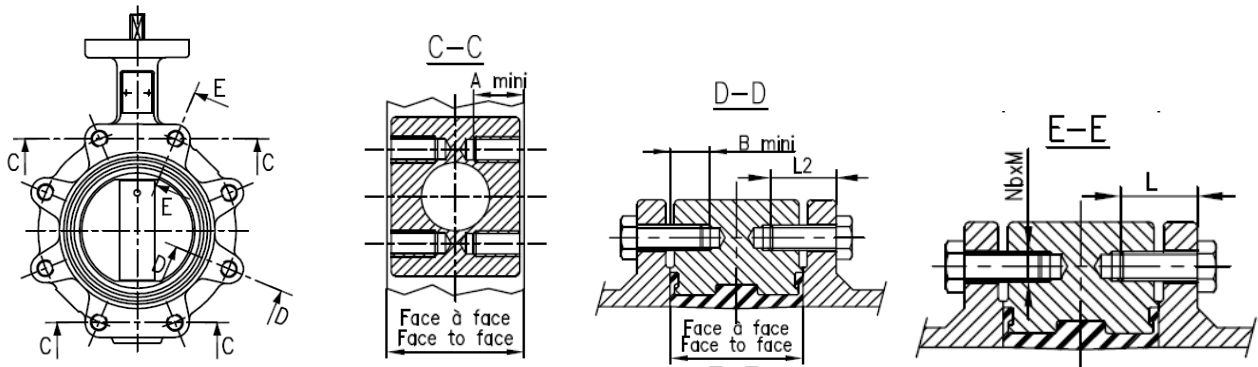

			500	550	600	650	700	750	800
ISO7005-1 EN1092-1&2	PN6	A	56		70		52		65
		B	56		70		70		70
		Nb	20		20		24		24
		M	M20		M24		M24		M27
		L2	80		100		80		100
		Nb							
		L							
ISO7005-1 EN1092-1&2	PN10	A	56		70		52		65
		B	56		70		70		70
		Nb	20		20		24		24
		M	M24		M27		M27		M30
		L2	80		100		80		100
		Nb							
		L							
ISO7005-1 EN1092-1&2	PN16	A	56		70		52		70
		B	56		70		70		70
		Nb	20		20		24		20+
		M	M30		M33		M33		M36
		L2	80		100		80		110
		Nb							2x4
		L							100
ISO7005-1 EN1092-1&2	PN25	A	56		70		52		70
		B	56		70		70		70
		Nb	20		20		24		24
		M	M33		M36		M39		M45
		L2	90		110		100		120
		Nb							
		L							

Rev / Date	A	01/17	B	05/26													
												ROBINET A PAPILLON BUTTERFLY VALVE				159787 17/25 JANVIER 2017	

Heavy duty resilient seated butterfly

DN500 /DN800

			500	550	600	650	700	750	800
ISO7005-1 EN1759-1	PN20	A	56		70		45	50	60
		B	56		70		70	65	70
		Nb	20		20		24+	28	28
		M	M30		M33		M33	M33	M39
		L2	100		110		130	120	140
		Nb					2x4		
		L					110		
ASME B16.5 / B16.42 ASME B16.47 Serie A	Cl150	A	56		70		45	50	60
		B	56		70		70	65	70
		Nb	20		20		24+	28	28
		M	1"1/8		1"1/4		1"1/4	1"1/4	1"1/2
		L2	100		110		130	120	140
		Nb					2x4		
		L					110		
JIS B2210	JIS10K	A	56				52		
		B	56				70		
		Nb	20				24		
		M	M24				M30		
		L2	90				80		
		Nb							
		L							
JIS B2210	JIS16K	A	56				52		70
		B	56				70		70
		Nb	20				24		24
		M	M30				M39		M45
		L2	100				100		120
		Nb							
		L							

Rev / Date	A	01/17	B	05/26											
											ROBINET A PAPILLON BUTTERFLY VALVE			159787	18/25
														JANVIER 2017	

10.4. LUG : Compatibilité de raccordement / Flange drilling compatibility

	DN	500	550	600	650	700*	750*	800*
	Size	20"	22"	24"	26"	28"	30"	32"
ISO 7005 / EN1092-1	PN6							
	PN10							
	PN16							
	PN20					X		X
	PN25							
	PN40	X		X		X		X
CL150	ASME B16.1							
	ASME B16.5							
	ASME B16.42							
	ASME B16.47 A							
	MSS SP-44							
	API 605					X	X	X
AWWA C207	Table 2-3-4-5							
BS10	TABLE A	X		X			X	
	TABLE D	X		X			X	
	TABLE E	X		X			X	
JIS B2210	5K						X	
	10K			X			X	X
	16K			X			X	
	20K			X		X	X	X

	Raccordement possible	Flange drilling possible
X	Raccordement impossible	Flange drilling impossible
	Raccordement non défini par la norme	Flange drilling not defined by standard
*	4 trous taraudés non débouchant par face	4 un-tapped threaded holes per face

10.5. Couple de serrage / Tightening torque

M12		26 N.m	M30	1"1/8	430 N.m
M16	5/8"	63 N.m	M33	1"1/4	580 N.m
M20	3/4"	120 N.m	M36		750 N.m
M22		170 N.m	M39	1"1/2	970 N.m
M24	7/8"	210 N.m	M45	1"3/4	1500 N.m
M27	1"	310 N.m	M52	2"	2330 N.m

Rev / Date	A	01/17	B	05/26											
											ROBINET A PAPILLON BUTTERFLY VALVE			159787	19/25
														JANVIER 2017	

11. Installation / Assembly

11.1. Vitesse fluide / Fluid speed

Les robinets papillons sont conçus pour une vitesse d'écoulement maximale préconisée :

Butterfly valves are designed for a maximum recommended flow speed :

Pression de service Working pressure	Vitesse d'écoulement maximale préconisée / Max flow speed recommended	
	Fluide Liquide / Liquid	Fluide Gazeux / Gas
PS < 6 bar	2,5 m/s	25 m/s
PS < 10 bar	3 m/s	30 m/s
PS < 16 bar	4 m/s	35 m/s
PS < 25 bar	5 m/s	40 m/s

Conformément aux normes / Conform to standards : EN593 & EN1074

11.2. Installation / Assembly

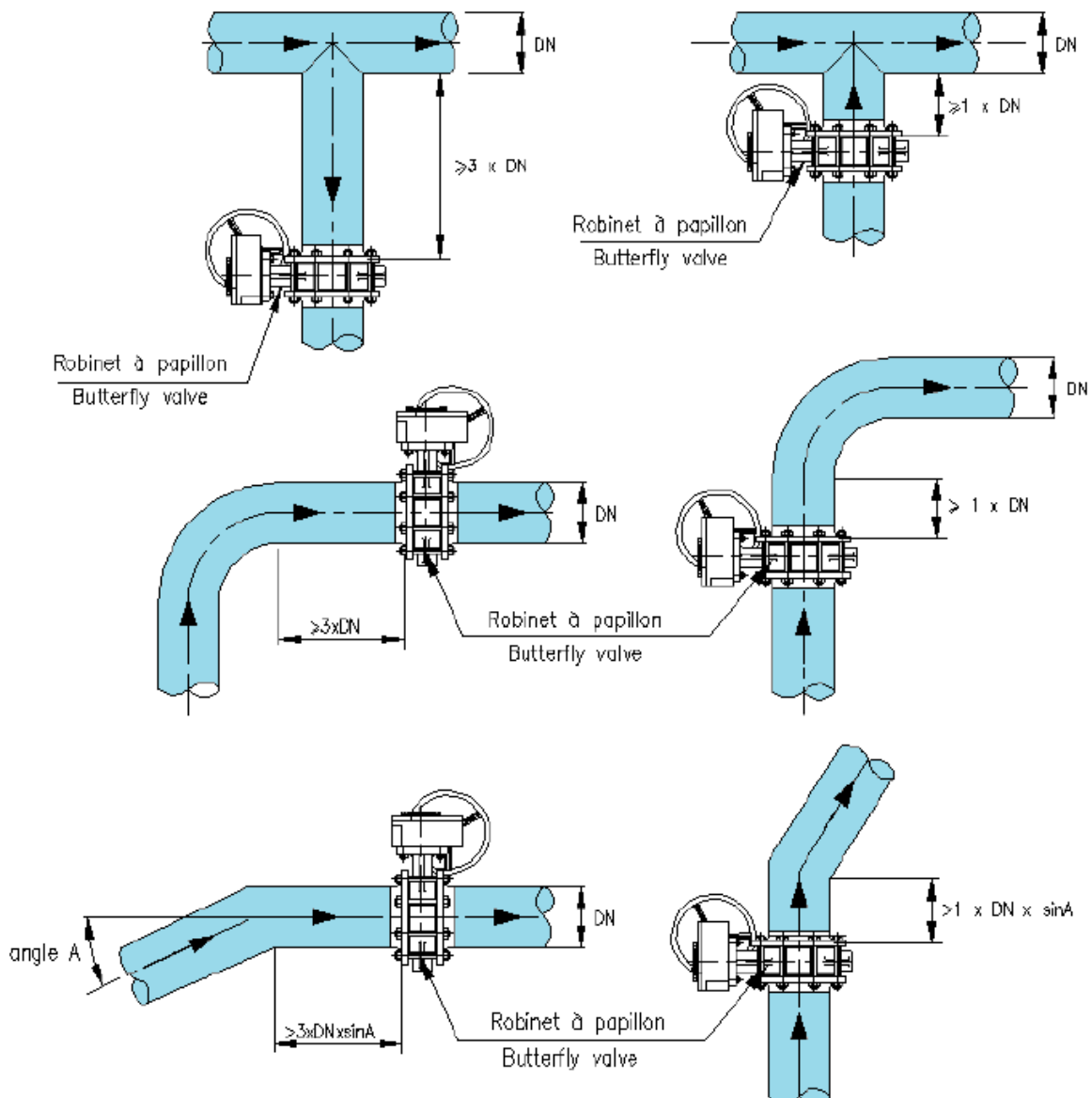

11.3. Orientation ligne d'arbre / Shaft orientation

Rev / Date	A	01/17	B	05/26											
												ROBINET A PAPILLON BUTTERFLY VALVE		159787	20/25
														JANVIER 2017	

Heavy duty resilient seated butterfly

DN500 /DN800

DN50 – DN600
NPS2” –NPS24”

Arbre vertical
vertical shaft

ou or

Arbre horizontal
horizontal shaft

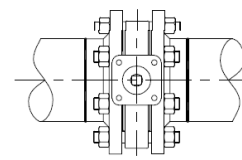
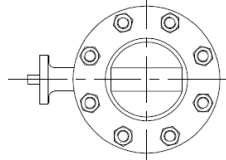
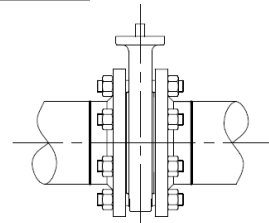
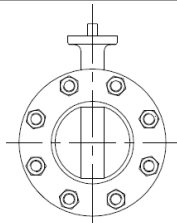

DN650 – DN1000
NPS25” –NPS40”

Arbre horizontal
horizontal shaft

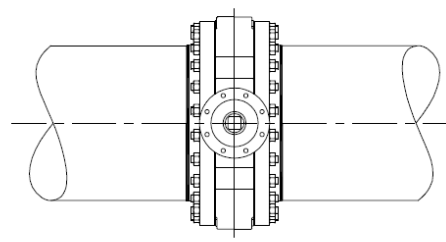
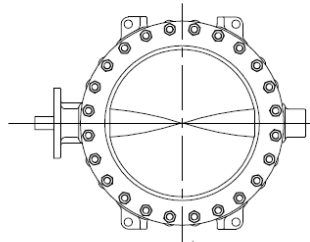

sur demande: arbre vertical / *on request vertical shaft*

- Vanne avec actionneur manuel uniquement
- Température Maxi 40°C
- Manchette EPDM ou Nitrile

- Valve with worm gear
- Temperature Maxi 40°
- Seat EPDM ou Nitrile

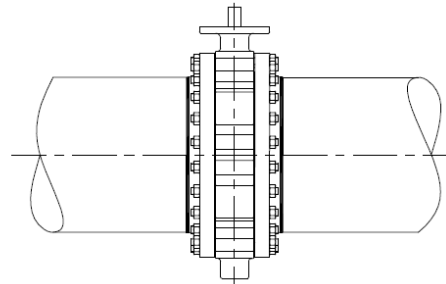
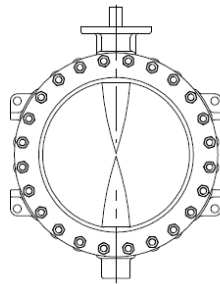

11.4. Instruction de montage / Assembly instruction

1 - Ménager un espace suffisant entre les brides de la tuyauterie pour éviter de blesser les joues de la manchette en glissant le robinet entre les deux brides.

1 - Make sure you have a sufficient space between flanges in order not to damage the seal.

DN	A min	B min
500	194,1	515,3
550	207,9	569,8
600	228,8	611,5
650	249,3	663,6
700	271,6	708,2
750	299,3	763,7
800	306,5	803

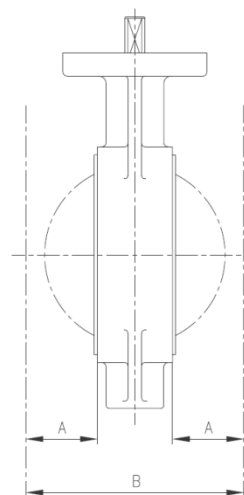

2 - Centrer le robinet à l'aide de la visserie. Serrer progressivement les tirants diamétralement opposés par

2 - Center the valve with the bolting. Progressively tighten bolts by alternating sides until you have contact between valve and flange faces.

Rev / Date	A	01/17	B	05/26										
												<p>ROBINET A PAPILLON</p> <p>BUTTERFLY VALVE</p>		<p>159787 21/25</p> <p>JANVIER 2017</p>

Heavy duty resilient seated butterfly

DN500 /DN800

alternance jusqu'à obtenir le serrage métallique du corps du robinet sur les faces de brides.



3 - Contrôle après montage : effectuer une ouverture et une fermeture complète du papillon pour s'assurer que rien ne s'oppose à son débattement.

3 - Control : operate valve from fully opened position to fully closed position to make nothing obstruct the disc.

11.5. Cotes des brides / Flanges dimensions

Cotes données pour un robinet parfaitement centré.

Brides à face surélevée : montage impossible avec brides PN 6

Les brides type 11 sont recommandées pour les pressions de service supérieure à 16 bar.

Dimensions for valve perfectly centered

Flanges with raised face : impossible mounting with PN 6 flanges

Type 11 flanges are recommended for working pressure above 16 bar.

DN	ØD mini	ØD maxi	ØF mini
500	475	516,5	585
550	530	560	625
600	570	616,5	685
650	624	665	740
700	670	713	800
750	726	767	905
800	765	815	905

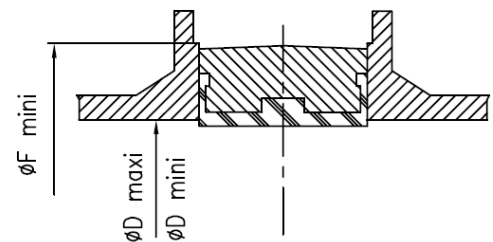

Lors d'un montage avec une tuyauterie de diamètre inférieure à celui de la vanne, un chanfrein sur la bride peut être requis.

When mounting with piping of smaller diameter than the valve, a chamfer on the flange may be required.

DN	ØA	α
500	475	15°
550	530	15°
600	570	15°
650	624	15°
700	670	15°
750	726	15°
800	765	15°

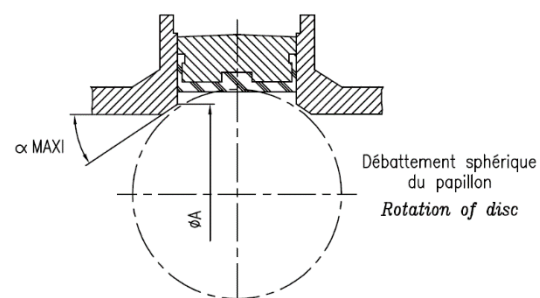

Rev / Date	A	01/17	B	05/26										
		ROBINET A PAPILLON BUTTERFLY VALVE										159787	22/25	
												JANVIER 2017		

Montage en bout de conduite / *Mounting a valve in a dead end service.*

11.5.1. Généralité / *General information*

Le montage en bout de conduit est autorisé uniquement pour les vannes classées au plus **Cat.1** (gaz ou liquide classé groupe II (non dangereux)) suivant les règles établies par la Directive Européennes des Equipements sous pression, et des installations sans régime de pression pulsatoire.

Le montage du robinet doit être effectué dans les règles de l'art ; Visserie en bon état sans oxydation.

*Installation at the end of the pipe is authorized only for valves classified **Cat.1 or less** (gas or liquid classified Group II (non dangerous)) in accordance with the rules laid down by the European Pressure Equipment Directive, and on installation without pulsating conditions.*

The valve shall be installed according to traditional rules; bolting shall be in good condition (no oxydation).

ATTENTION :

Pour des raisons de sécurité, le robinet à papillon utilisé dans ces conditions de montage, en bout de conduite, assure uniquement une fonction de bride pleine.

En position fermé l'organe de manœuvre doit être **verrouillé** afin d'éviter toute manœuvre non autorisée.

L'ouverture du robinet n'est possible qu'après avoir pris toutes les mesures de sécurité.

La pression maximale d'utilisation de la vanne en bout de conduite *PS(BdC)* sera, compte tenu de la pression de service *PS* de la vanne en conduite limité à :

WARNING :

For safety reasons, the butterfly valve used in these mounting conditions (dead end service) only serves as a blind flange function.

In the closed position the actuator must be **locked** in order to prevent unauthorized maneuvering.

Valves can be operated again only after taking all safety precautions.

The maximum operating pressure of the valve at the end of the pipe *PS(BdC)* will be, taking into account the working pressure *PS* of the valve in driving limited to:

$$PS(BdC) = PS \times 0.733$$

PS / WP (bar)	PS(BdC) (bar)
6	4,4
10	7,3
16	11,7
20	14,6
25	18,3

11.5.2. Cas des vannes Wafer / *Wafer valves case*

Tous les éléments de serrage doivent être montés, ainsi que des rondelles sous écrou pour le Montage Wafer.

La pression maximale admissible PMA pour un montage wafer **avec** contre bride est comme indiqué précédemment.

La pression maximale admissible PMA pour un montage wafer **SANS** contre bride est limitée à

All bolts must be mounted, also washers under nuts for Wafer mounting.

This assembly must be carried out by monitoring the tightening torque of the 4 tie rods, this torque must be a maximum of:

DN	PMA / MWP
450-600	1 bar
700-1000	0 bar

Rev / Date	A	01/17	B	05/26											
												ROBINET A PAPILLON BUTTERFLY VALVE		159787	23/25
														JANVIER 2017	

12. Démontage ou montage tuyauterie amont ou aval / Dismantling - mounting pipe

AVERTISSEMENTS :	WARNING:
A - Ces instructions sont applicables aux vannes type WAFER pour les tirants traversant les oreilles. Les autres tirants seront démontés après application du 1.1 ou du 1.2, et remontés avant application du 2.1 ou du 2.2.	A - These instructions are applicable to WAFER type valves for tie rods through the ears. The other tie-rods will be dismantled after application of 1.1 or 1.2 and rebuilt before application of 2.1 or 2.2.
B - Vérifier que les tuyauteries amont et aval sont à la pression atmosphérique.	B - Check that the upstream and downstream piping are at atmospheric pressure
C - Vérifier que le robinet est en position fermé	C - Check that the valve is in the closed position
D - Vérifier que la tuyauterie à démonter a été vidangée ou que les dispositions adéquates compte tenu de la réglementation locale ont été prises afin d'assurer l'évacuation du fluide résiduel en toute sécurité.	D - Verify that the piping to be disassembled has been drained or that proper arrangements have been made in accordance with local regulations to ensure safe disposal of the waste fluid.
E - Vérifier que les éléments de tuyauterie sont soutenu ou suspendu de manière sure.	E - Check that the piping elements are securely supported or suspended.

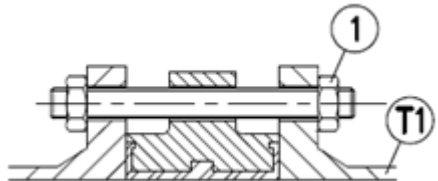
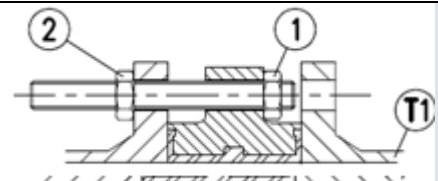
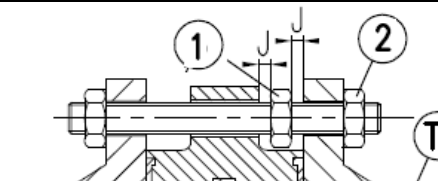
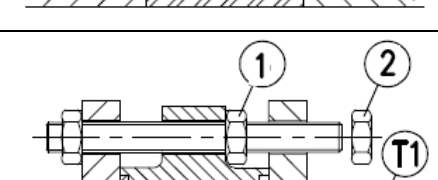
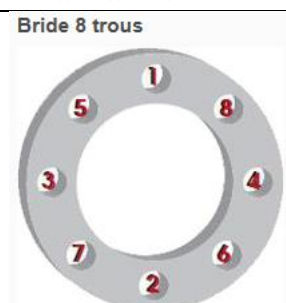
Démontage de la tuyauterie(T1)			Pipe (T1) diassembly
	Cas N°1		Case N°1
1.1a	-Démontez l'écrou (1) -Déplacer le tirant -Remonter l'écrou (1) -Serrer l'écrou		- Remove nut (1) - Move through bolt - Put nut(1) - Tight nut
	Cas N°2		Case N°2
1.1b	-Serrer l'écrou (1) -Démontez l'écrou		- Tight nut (1) - Remove nut
1.2	- Procéder comme au 1.1a ou 1.1b sur le tirant diamétralement opposé - Procéder de même par alternance un tirant sur deux - Déposer la tuyauterie (T1)		- Proceed as in 1.1a or 1.1b on the diametrically opposite tie rod - Proceed in the same way by alternating one tie rod - Remove the piping (T1)

Montage de la tuyauterie (T1)			Pipe (T1) assembly
-------------------------------	--	--	--------------------

	Placer la tuyauterie (T1) contre le robinet		Put the pipe (T1) against the valve.
2.1a	<p>Cas N°1</p> <ul style="list-style-type: none"> -Démonter l'écrou (1) -Déplacer le tirant -Remonter l'écrou (1) -Serrer l'écrou 		<p>Case N°1</p> <ul style="list-style-type: none"> - Remove nut (1) - Move through bolt - Put nut(1) - Tight nut
2.1b	<p>Cas N°2</p> <ul style="list-style-type: none"> -Monter l'écrou -Serrer l'écrou -Desserrer l'écrou (1) 		<p>Case N°2</p> <ul style="list-style-type: none"> - Put nut - Tight nut - Untight nut (1)
2.2	<ul style="list-style-type: none"> - Procéder comme au 1.2a sur le tirant diamétralement opposé - Procéder de même par alternance un tirant sur deux 	<p>Bride 8 trous</p>	<ul style="list-style-type: none"> - Proceed as in 1.2a on the diametrically opposite tie rod - Proceed in the same way by alternating one tie rod

13. Conditions de stockage / Storage conditions

Il conviendra de prendre toutes les précautions d'usage lors de la manutention et du stockage des équipements à savoir :

- Stockage à l'intérieur des bâtiments (température $\geq 6^\circ$) sous l'emballage d'origine.
- Les opérations de manutention à des températures inférieures devront être entreprises occasionnellement en évitant expressément les chocs et les contraintes sur le matériel. De préférence, procéder à ces manutentions sous emballage.
- Veiller lors du déballage à ne pas endommager les portées de joints. Manipuler les appareils avec précaution.
- Les vannes comportant des élastomères doivent être entreposées à l'abri de la lumière et de la chaleur.

It will be necessary to take all the precautions of use during the handling and the storage of the equipment namely:

- Storage inside buildings (temperature $\geq 6^\circ$) under the original packaging.
- Handling operations at lower temperatures should be carried out occasionally, specifically avoiding shocks and stresses on the equipment. Preferably, carry out these handling operations under packaging.
- When unpacking, do not damage the sealing surfaces. Handle devices with care.
- Valves with elastomers must be stored away from light and heat.

Rev / Date	A	01/17	B	05/26													
			<p align="center">ROBINET A PAPILLON</p> <p align="center">BUTTERFLY VALVE</p>										<p align="right">159787 25/25</p> <p align="right">JANVIER 2017</p>				