

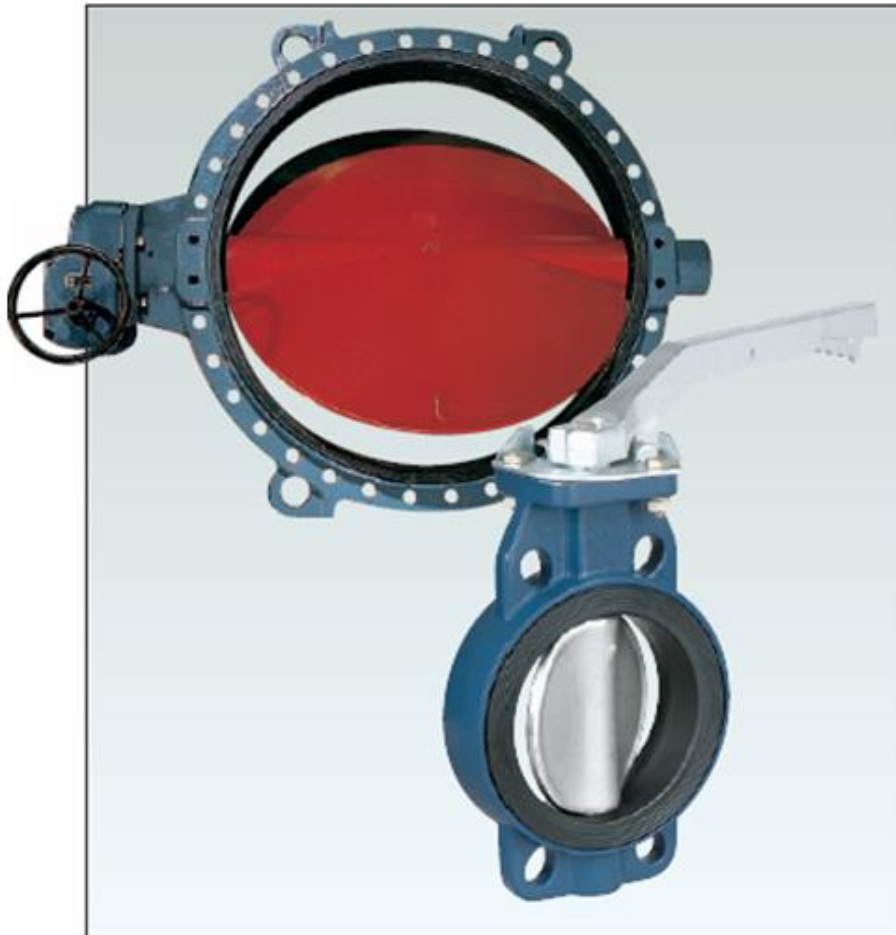

---

# JMC

## DN1050-DN1600(PMA10)

---



Rev / Date	A	01/17	B	09/23	C	10/23	D	05/26											
												<b>ROBINET A PAPILLON</b>				159789	1/19		
												<b>BUTTERFLY VALVE</b>				JANVIER 2017			

### Table des matières

1.	NOMENCLATURE / PART LIST.....	3
2.	DOUBLE BRIDE DIMENSIONS / <i>DOUBLE FLANGE DIMENSIONS</i> .....	4
3.	MONTAGE ENTRE BRIDES / ASSEMBLY BETWEEN FLANGES .....	5
4.	Caractéristiques hydrauliques Kv / Hydraulics characteristics Kv .....	6
6.1	Tableau des coefficients de débits / <i>Flow characteristics chart</i> .....	6
6.2	Caractéristiques de débits intrinsèque / Intrinsic flow characteristics .....	6
6.3	Formules simplifiées / Simplified formula .....	7
5.	PRESSION MAXIMUM DE CONCEPTION / <i>MAXIMUM DESIGN PRESSURE</i> .....	8
6.	MANCHETTE / SEAT.....	9
7.	PAPILLON REVÊTU / <i>COATED DISC</i> .....	10
8.	Etanchéité / Tightness.....	10
8.1	<i>Essai de fin de production / Production Control test</i> .....	10
8.2	<i>Tenue au vide / Vacuum limits (FT159615)</i> .....	10
9.	COUPLE / TORQUE .....	11
9.1	<i>Couple de manœuvre / Operating torque</i> .....	11
9.2	<i>Couple maximum admissible / maximum operating torque</i> .....	12
10.	MONTAGE ENTRE BRIDES / ASSEMBLY BETWEEN FLANGES .....	13
	10.1 DOUBLE BRIDE / DOUBLE FLANGE : Compatibilité de raccordement / <i>Flange drilling compatibility</i> .....	14
	10.2 Couple de serrage / Tightening torque.....	14
11.	INSTALLATION / ASSEMBLY.....	15
11.1	<i>Vitesse fluide / Fluid speed</i> .....	15
11.2	<i>Installation / Assembly</i> .....	15
11.3	<i>Orientation ligne d'arbre / Shaft orientation</i> .....	16
11.4	<i>Instruction de montage / Assembly instruction</i> .....	16
11.5	<i>Cotes des brides / Flanges dimensions</i> .....	17
11.6	<i>Montage en bout de conduite / Mounting a valve in a dead end service</i> .....	18
12.	Démontage ou montage tuyauterie amont ou aval / Dismantling - mounting pipe .....	19
13.	Conditions de stockage / Storage conditions .....	19

Rev / Date	A	01/17	B	09/23	C	10/23	D	05/26							
											<b>ROBINET A PAPILLON</b> <b>BUTTERFLY VALVE</b>			159789	2/19
														JANVIER 2017	

## 1. NOMENCLATURE / PART LIST

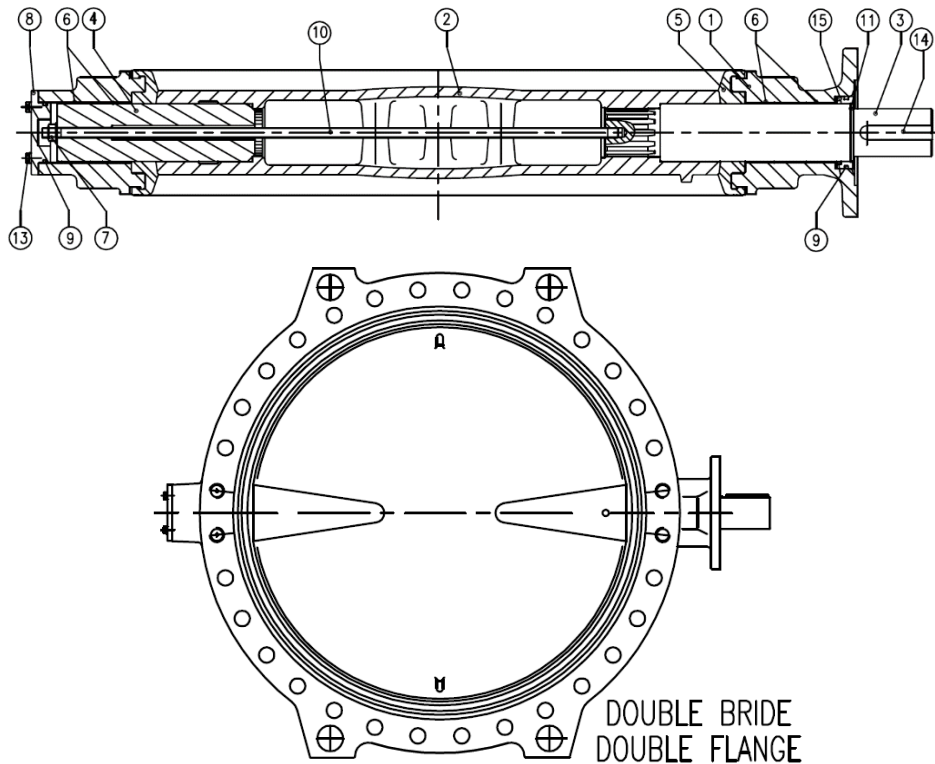

Rep Item	Nb	DESIGNATION	MATIERE / MATERIALS *
1	1	CORPS / BODY	Fonte GS : EN-GJS 400-18 - Revêtu Epoxy
			Ductile Iron : ASTM A536 Grade 60.40.18 - Epoxy Coated
			Acier au Carbon / Carbon Steel : ASTM A216 Grade WCB
			Acier Inoxydable / Stainless Steel : ASTM A351 CF8M
2	1	PAPILLON / DISC	Fonte GS : EN-GJS 400-18 - Revêtu Epoxy
			Ductile Iron : ASTM A536 Grade 60.40.18 - Epoxy Coated
			Acier Inoxydable / Stainless Steel : ASTM A351 CF8M (1.4401)
			Cupro-Aluminium / Aluminum Bronze : ASTM B148 UNS C95800 NF EN 1982 CC333G
3	1	ARBRE / SHAFT	Acier à 13% Cr / Stainless Steel 13% Cr / AISI 240 / 1.4021
4	1	AXE / SPINDLE	
5 **	1	MANCHETTE / SEAL	EPDM / NBR / FPM-FKM
6	4	PALIER / BEARING	Acier revêtu PTFE/ Carbon Steel PTFE Lined
7	1	ECROU / NUT	Acier Inoxydable + Polyamide / Stainless Steel + Polyamide
8	1	COUVERCLE / BONNET	Acier au Carbon / Carbon Steel
9**	3	JOINT TORIQUE / O-RING SEAT	Nitrile
10	1	TIRANT / THRU-BOLT	Acier Inoxydable / Stainless Steel
11	3	JONC / RUSH	Acier à Ressort / Steel
12	1	ETIQUETTE / IDENTIFICATION PLATE	Acier Inoxydable / Steel
13	4	VIS + RONDELLE / SCREW + WASHER	Acier Zingué / Zinc Coated Steel
14	1	CLAVETTE / KEY	Acier au Carbon / Carbon Steel
15	1	MANCHON / BUSHING	Laiton / Brass

* : Autres matériaux disponibles sur demande Others materials and grades available on request	Désignation matières standards Usual materials and grades
** : Pièces de rechange / Spare parts	
Certificats 3.1B sur demande, pour les corps, papillons, arbre et axes. 3.1B Certificates on request, for body, disc, shaft and spindle.	

Rev / Date	A	01/17	B	09/23	C	10/23	D	05/26									
												<b>ROBINET A PAPILLON</b> <b>BUTTERFLY VALVE</b>				159789	3/19
												JANVIER 2017					

### 2. DOUBLE BRIDE DIMENSIONS / DOUBLE FLANGE DIMENSIONS

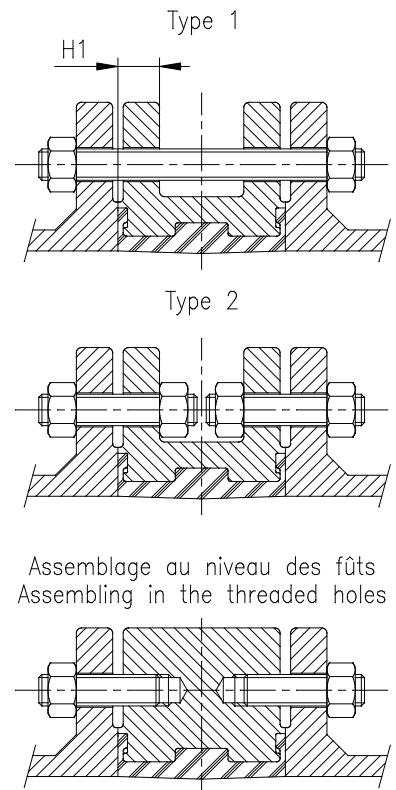
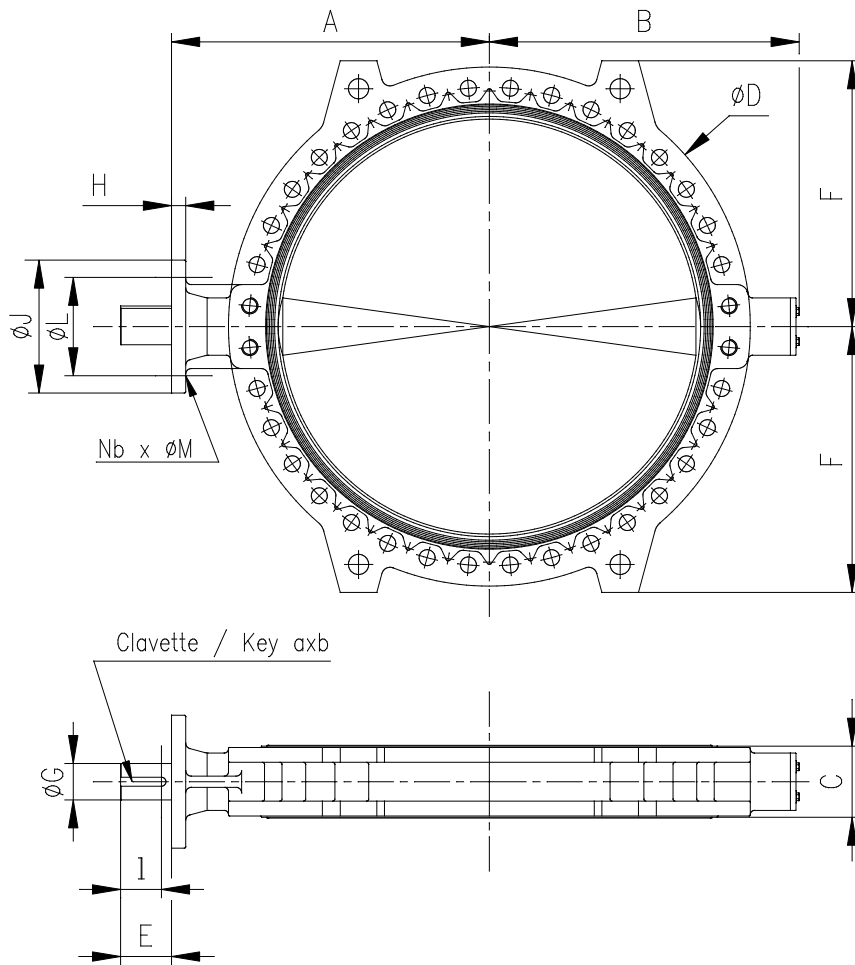

DN	A	B	C	H1	ØD	E	F	ØG	H	ØJ	ØL	Nb	ØM	BRIDE DE MOTORISATION ACTUATOR FLANGE			CLAVETTE KEY			POIDS WEIGHT
														a	b	l	a	b	l	
1050	780	770	254	48	1340	130	695	100	30	350	298	8	22	28	16	120	1100			
1100	820	805	254	50	1400	130	710	100	30	350	298	8	22	28	16	120	1199			
1200	870	830	254	53	1490	130	760	100	30	350	298	8	22	28	16	120	1276			
1300	960	935	254	53	1625	140	835	120	40	415	356	8	32	32	18	130	1672			
1350	987	965	254	53	1685	140	865	120	40	415	356	8	32	32	18	130	1716			
1400	1015	1000	254	55	1690	140	865	120	40	415	356	8	32	32	18	130	1749			
1500	1130	1090	254	58	1855	180	950	130	50	475	406	8	38	32	18	160	2134			
1600(10)	1170	1135	254	60	1930	180	980	130	50	475	406	8	38	32	18	160	2211			

Dimension [mm], masse [kg] sont données à titre indicatif seulement  
 Dimension [mm], masse [kg] are given as a guide only

Montage entre brides :

- Raccordement brides PN10 PN16 normalisées
- Type d'assemblage possible 1 ou 2
- Assemblage PN25 : type 1 uniquement

To be mounted between flanges to:

- ISO PN10 – ISO PN16 (other on request)
- Assembling possible type 1 or 2
- Assembling PN25: type 1 only

Rev / Date	A	01/17	B	09/23	C	10/23	D	05/26											
														<b>ROBINET A PAPILLON</b> <b>BUTTERFLY VALVE</b>				159789	4/19
<b>JANVIER 2017</b>																			

## 3. MONTAGE ENTRE BRIDES / ASSEMBLY BETWEEN FLANGES

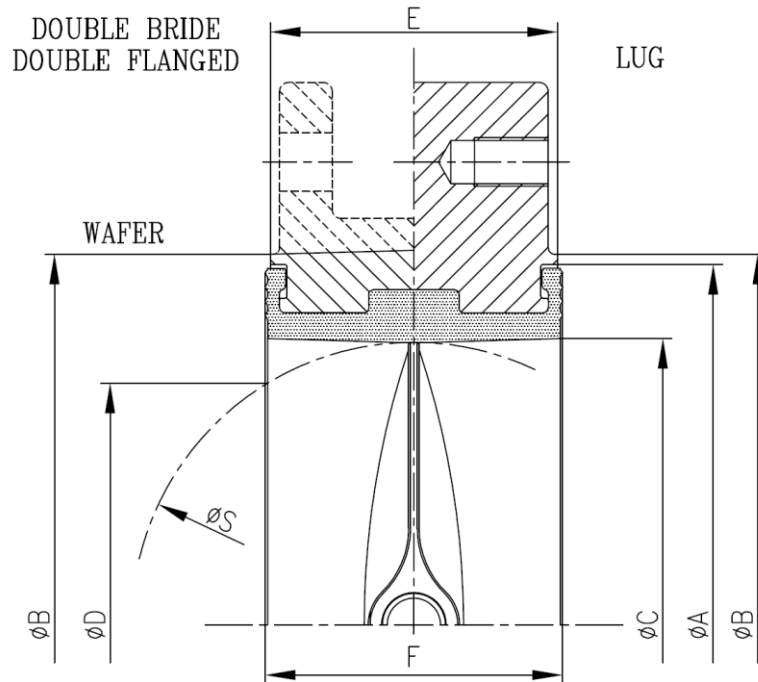

DN	1050	1100	1200	1300	1350	1400	1500	1600(10)	1600(16)
NPS	42	44	48	52	54	56	60	64	64
ØA	1115	1184	1282	1381	1445	1493	1591	1693	1713
Øb	1150	1200	1320	1410	1461	1510	1620	1730	1730
ØC	1027	1096	1194	1293	1335	1404	1503	1604	1598
ØD	979	1050	1150	1252	1315	1364	1466	1567	1537
E	254	254	254	254	254	254	254	254	356
F	260	260	260	260	260	260	260	260	362
ØS	1011	1080	1188	1277	1340	1388	1488	1588	1560

Dimensions [mm], masse [kg] sont données à titre indicatif seulement.

Dimensions [mm], masse [kg] are given as a guide only.

Rev / Date	A	01/17	B	09/23	C	10/23	D	05/26							
											<b>ROBINET A PAPILLON</b> <b>BUTTERFLY VALVE</b>			159789	5/19
											JANVIER 2017				

## 4. Caractéristiques hydrauliques Kv / Hydraulics characteristics Kv

### 6.1 Tableau des coefficients de débits / Flow characteristics chart

DN	20°	30°	40°	50°	60°	70°	80°	90°
1050	2847	5684	9482	17063	26556	50241	86186	94809
1100	3093	6186	10310	18558	28868	54643	93718	103100
1200	3722	7428	12390	22300	34703	65657	112630	123900
1300	4099	7613	14202	25770	40016	75640	129815	146240
1350	4520	8335	15539	28074	43364	82389	141548	159556
1400	4940	9056	16876	30377	47252	89318	153280	172872
1500	5504	10287	19190	34818	54067	102198	175396	197830
1600	6452	11828	22042	39676	61717	116660	200203	225792

### 6.2 Caractéristiques de débits intrinsèque / Intrinsic flow characteristics

Le débit intraseque est inscrit dans la zone hachurée suivante :

*Intrinsic flow characteristics are included in below hachured area :*

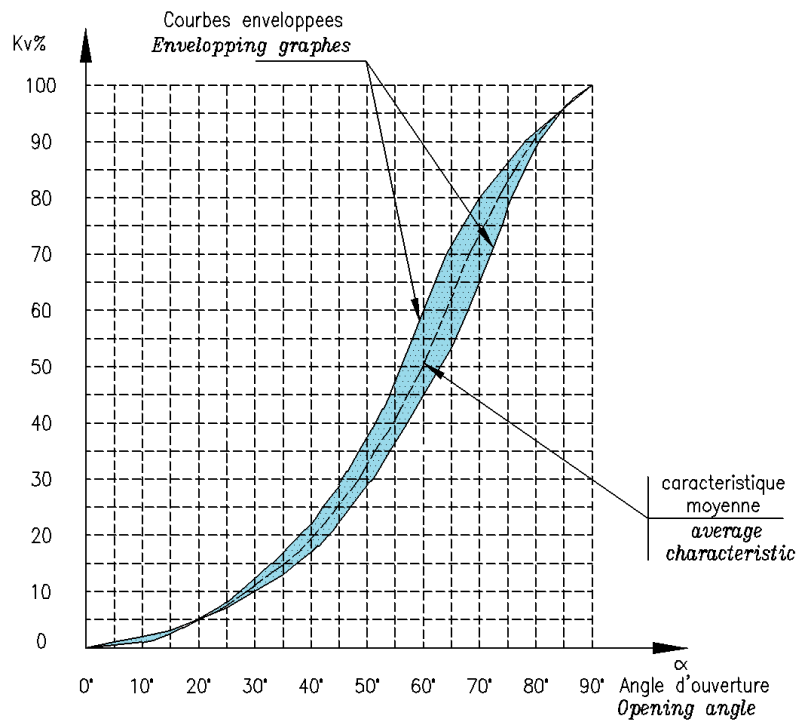

Rev / Date	A	01/17	B	09/23	C	10/23	D	05/26							
											<b>ROBINET A PAPILLON</b> <b>BUTTERFLY VALVE</b>			159789	6/19
											JANVIER 2017				

### 6.3 Formules simplifiées / Simplified formula

Elles permettent de calculer la perte de charge du robinet en fonction des conditions d'écoulement, ou de définir le dimensionnement du robinet (réglage) entre 20° et 70°

*They make it possible to calculate the pressure drop of the valve according to the flow conditions, or to define the dimensioning of the valve (setting) between 20 ° and 70 °*

Perte de charge		Fluides incompressibles	Gaz
<i>Headloss</i>		<i>Incompressible fluids</i>	<i>Gas</i>
$\Delta P < \frac{P_1}{2}$ $P_2 > \frac{P_1}{2}$	K <sub>v</sub>	$= \frac{Q}{31,6} \sqrt{\frac{\rho_1}{\Delta P}}$	$= \frac{Q}{514} \sqrt{\frac{\rho_{N.T}}{\Delta P \cdot P_2}}$
$\Delta P > \frac{P_1}{2}$ $P_2 < \frac{P_1}{2}$			$= \frac{2 \cdot Q_N}{514 \cdot P_1} \sqrt{\rho_{N.T}}$

Kv		Coefficient de débit	Flow coefficient
Q	m3/h	Débit	Flow rate
ΔP	Bar	Perte de charge	Headloss
P1	Bara	Pression amont absolue	Absolute upstream pressure
P2	Bara	Pression aval	Absolute downstream pressure
Q	m3/h	Débit normal (0° / 1 atm)	Normal flow rate (0° / 1 atm)
T	°K	Temperature absolue	Absolute temperature
	Kg/m3	Masse volumique	Volumic weight
	Kg/m3	Masse volumique normal (0° / 1 atm)	Normal volumic weight (0° / 1 atm)

Ces formules peuvent être utilisées uniquement lorsque le diamètre de la vanne est égal au diamètre de la conduite.

*These formulas can be used only when valve diameter is the same as pipe diameter.*

Rev / Date	A	01/17	B	09/23	C	10/23	D	05/26								
												<b>ROBINET A PAPILLON</b> <b>BUTTERFLY VALVE</b>			159789	7/19
												<b>JANVIER 2017</b>				

## 5. PRESSION MAXIMUM DE CONCEPTION / MAXIMUM DESIGN PRESSURE

Corps / Body	Papillon / Butterfly disc
Fonte ductile / <i>Ductile iron</i> Acier au carbone / <i>Carbon steel</i>	Acier Inoxydable / <i>Stainless steel</i> Cupro-aluminium / <i>Aluminum bronze</i> Fonte ductile revêtu Epoxy / <i>Ductile iron, Epoxy coated</i> Fonte ductile revêtu Rilsan / <i>Ductile iron, Rilsan coated</i> Fonte ductile revêtu Halar / <i>Ductile iron, Halar coated</i>

**Remarque :**

- La courbe pression / température de la vanne est définie par la manchette, la matière du papillon, le revêtement du papillon, et la bride de raccordement.
- Vérifier la compatibilité des corps avec les brides de raccordement

**Note:**

- The valve pressure / temperature curve of the valve is defined by the sleeve, the butterfly disc material, the butterfly disc coating and the flange drilling.
- Check the compatibility with the flanges drilling.

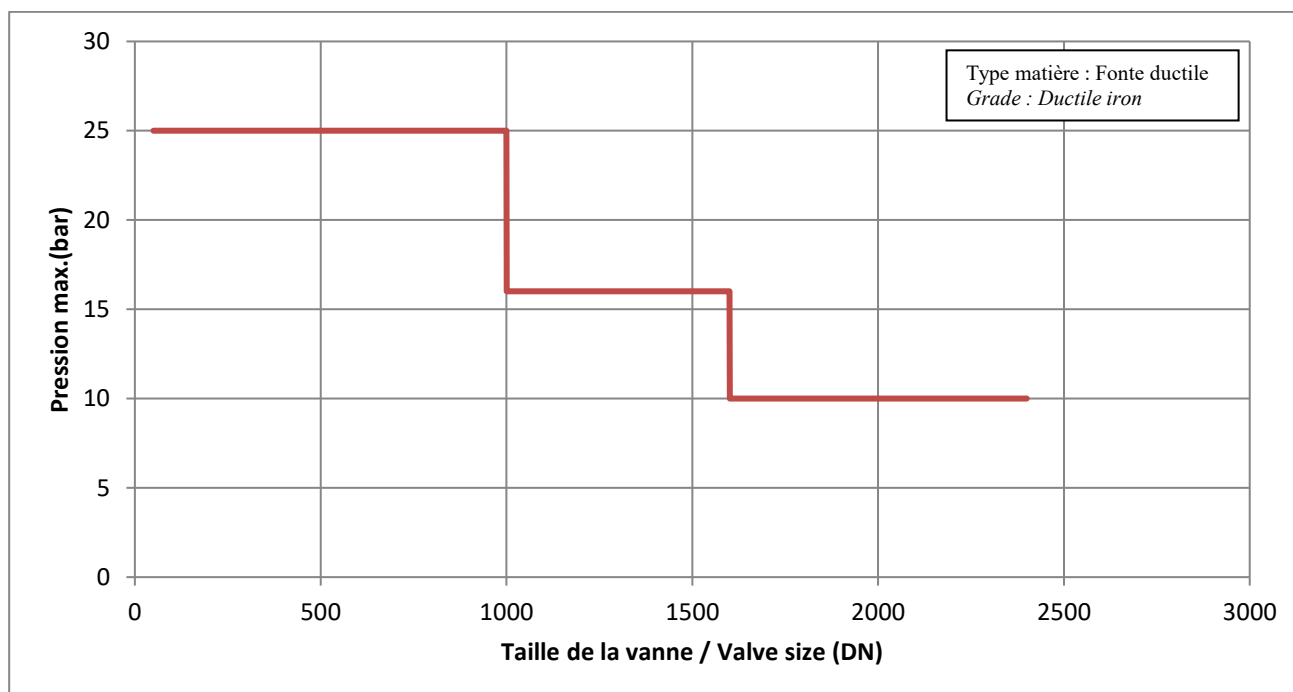

Rev / Date	A	01/17	B	09/23	C	10/23	D	05/26								
												<b>ROBINET A PAPILLON</b> <b>BUTTERFLY VALVE</b>			159789	8/19
															<b>JANVIER 2017</b>	

### 6. MANCHETTE / SEAT

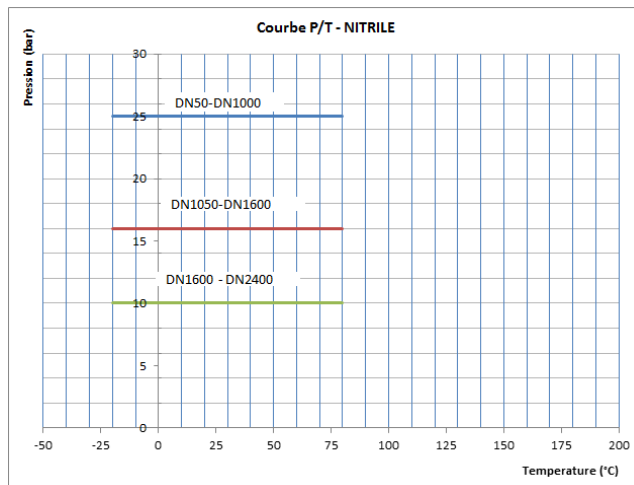
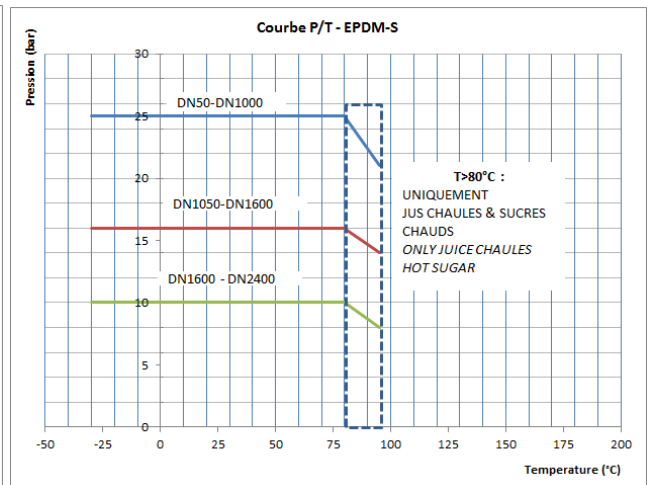
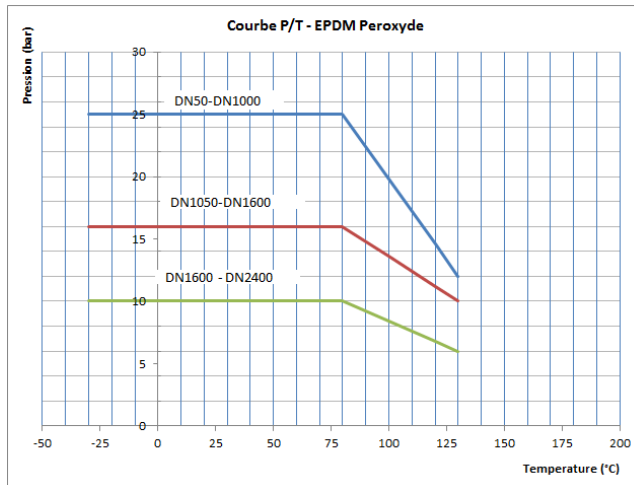

Rev / Date	A	01/17	B	09/23	C	10/23	D	05/26						
											<b>ROBINET A PAPILLON</b> <b>BUTTERFLY VALVE</b>			159789    9/19 JANVIER 2017

### 7. PAPILLON REVÊTU / COATED DISC

		DN		Temperature		Epaisseur Thickness ( $\mu$ m)	Pmax	F.T. / D.S.
		De/ From	A / to	Min.	Max			
Fonte ductile revêtu EPOXY	<i>Ductile iron EPOXY coated</i>	50	2400	-10°C <sup>(1)</sup>	+80°C	80		154451
Fonte ductile revetu RILSAN	<i>Ductile iron RILSAN coated</i>	50	2400	-10°C <sup>(1)</sup>	+80°C <sup>(2)</sup>	80		154450
Fonte ductile revetu HALAR	<i>Ductile iron HALAR coated</i>	50	2400	-10°C <sup>(1)</sup>	+80°C	600		159541
Fonte ductile revetu EBONITE	<i>Ductile iron EBONITE coated</i>	50	300	-5°C	+80°C	3000		159509
		350	450	+5°C	+95°C			
		500	2400					

<sup>(1)</sup> Limitation due à la fonte ductile FGS 400-15 / Restriction due to ductile iron FGS 400-15

<sup>(2)</sup> Pic de température / Temperature peaks : 110°C

### 8. Etanchéité / Tightness

#### 8.1 Essai de fin de production / Production Control test.

La JMC est un robinet bidirectionnel sans sens préférentielle d'écoulement.

*The JMC is a bidirectional valve without preferential flow direction.*

L'étanchéité du siège est :

*Seat tightness is :*

**EN12266-1 – Taux A**

**EN12266-1 – Rate A**

#### 8.2 Tenue au vide / Vacuum limits (FT159615)

DN	Construction / Design	Pression minimale / Minimal pressure	Pression maximale / Maximal pressure	Type de manchette / Seat material
800-1200	Standard	0,3 bar(a) 225 torr(a)	10 bar(g)	EPDM NBR
	Collé / Glued	$1,33 \cdot 10^{-5}$ bar(a) $10^{-2}$ torr(a)	6 bar(g)	EPDM NBR
1300 - 2400	Standard	1 bar(a) 750 torr(a)	6 bar(g)*	EPDM NBR
	Collé / Glued	$1,33 \cdot 10^{-3}$ bar(a) 1 torr(a)	6 bar(g)*	EPDM NBR

Rev / Date	A	01/17	B	09/23	C	10/23	D	05/26							
												<b>ROBINET A PAPILLON</b> <b>BUTTERFLY VALVE</b>		159789	10/19
<b>JANVIER 2017</b>															

### 9. COUPLE / TORQUE

#### 9.1 Couple de manœuvre / Operating torque

DN	Nominal (N.m)	CN/2 (N.m)
1050	8 000	5 333
1100	10 500	7 000
1200	15 000	10 000
1300	22 500	15 000
1350	27 000	18 000
1400	31000	20 667
1500	38 000	25 333
1600	46 000	30 667

Les couples sont donnés pour des pressions standard.

*The torque values are given for standard pressures.*

**Nota :**

Ces couples sont donnés pour des manchettes en EPDM, et tiennent compte des phénomènes de lubrification dû aux fluides (hors pulvérulents), du phénomène de fluide en température et de l'usure dans le temps.

Couple CN/2 : Construction couple réduit à 6 bar maximum (Manchette EPDM ou NBR)

Papillons revêtus ébonite ou caoutchouc, prévoir +30% aux valeurs ci-dessus.

Manchette Nitrile : prévoir +30% aux valeurs ci-dessus

Autres : Consulter l'usine.

**Note:**

*These torque values are given for EPDM sleeves and take into account lubrication due to fluids (excluding powders), fluid temperature variations, and wear over time.*

*CN/2 Torque: Reduced torque construction up to a maximum of 6 bar (EPDM or NBR sleeve).*

*For ebonite or rubber coated butterflies, add 30% to the values above.*

*For nitrile sleeves, add 30% to the values above.*

*Others: Please contact manufacturer.*

Rev / Date	A	01/17	B	09/23	C	10/23	D	05/26							
											<b>ROBINET A PAPILLON</b> <b>BUTTERFLY VALVE</b>			159789	11/19
														<b>JANVIER 2017</b>	

### 9.2 Couple maximum admissible / maximum operating torque

DN	Embase Top Flange	Couple max embase suivant ISO 5211 Max torque flange According ISO 5211	Connection Arbre/Shaft	Couple de rupture (N.m) Breaking torque (N.m)				
				Acier Inoxydable Stainless Steel 1.4021 Type 13%Cr	Acier Inoxydable Stainless Steel 1.4542 Type 17- 4Ph	Cupro- aluminium Aluminum bronze	Alliage nickel Nickel alloy 2.4375 Type Monel K500	Alliage nickel Nickel alloy 2.4856 Type Inconel 625
1050	F30	16 000 N.m	Ø 100	100 600	112 200	50 300	100 600	64 200
1100	F30	16 000 N.m	Ø 100	100 600	112 200	50 300	100 600	64 200
1200	F30	16 000 N.m	Ø 100	100 600	112 200	50 300	100 600	64 200
1300	F35	32 000 N.m	Ø 120	100 600	112 200	50 300	100 600	64 200
1350	F35	32 000 N.m	Ø 120	100 600	112 200	50 300	100 600	64 200
1400	F35	32 000 N.m	Ø 120	100 600	112 200	50 300	100 600	64 200
1500	F40	63 000 N.m	Ø 130	100 600	112 200	50 300	100 600	64 200
1600(10)	F40	63 000 N.m	Ø 130	214 100	238 800	107 100	214 100	136 700
1600(16)	F40	63 000 N.m	Ø 150	214 100	238 800	107 100	214 100	136 700

Boulons sollicités en traction à 290 MPa et coefficient de frottement de 0,2

Bolts in tensions only with a stress of 290 MPa and coefficient of friction of 0,2

Rev / Date	A	01/17	B	09/23	C	10/23	D	05/26									
												<b>ROBINET A PAPILLON</b> <b>BUTTERFLY VALVE</b>				159789	12/19
<b>JANVIER 2017</b>																	

### 10. MONTAGE ENTRE BRIDES / ASSEMBLY BETWEEN FLANGES

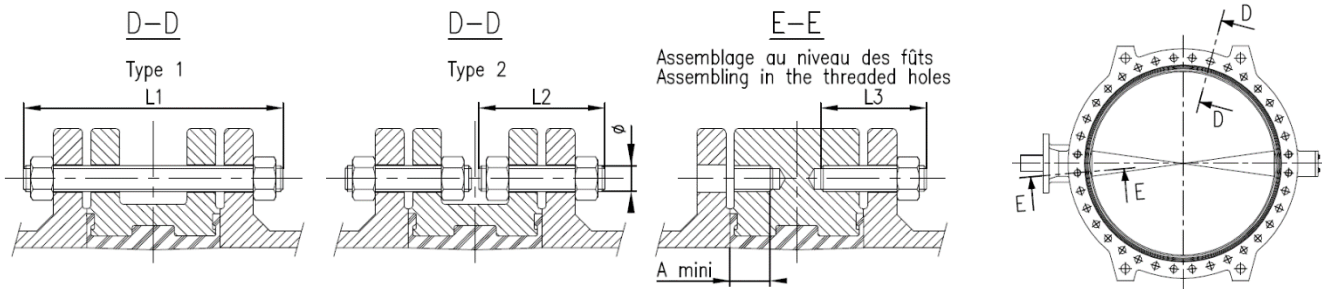

#### PN 6, 10, 16, 25

Longueur des vis calculées pour des brides en fonte ductile suivant NF EN 1092-2 et ISO 7005-2

Length of bolts calculate for cast iron flanges in accordance with NF EN 1092-2 and ISO 7005-2

La longitud de los pernos se calcula para bridas fundición s./ NF EN 1093-2 y ISO 7005-2

#### PN 20, Class 125, Class 150

Longueur des vis calculées pour des brides en acier suivant ISO 7005-1, ASME B16.47 série A et MSS SP-44

Length of bolts calculate for metallic flanges in accordance with ISO 7005-1, ASME B16.47 series A and MSS SP-44

La longitud de los pernos se calcula par bridas métalliques s./ ISO 7005-1, ASME B16.47 serie A y MSS SP-44

	DN	1100			1200			1300			1400			1500			1600 (10)		
		L1	L2	L3	L1	L2	L3	L1	L2	L3	L1	L2	L3	L1	L2	L3	L1	L2	L3
<b>PN 6</b> EN 1092-1 ISO 7005-1	Nombre de trous Number of bolt holes	24	2x24	2x4	28		2x4	32	2x28	2x4	32	2x32	2x4	32	2x32	2x4	36	2x36	2x4
	Ø boulonnerie Ø of bolts	M30			M30			M33			M33			M39			M45		
	Longueur mini des tirants Mini length of thru-bolts	410	165	155	405		160	415	175	145	415	175	145	445	195	170	455	215	165
	A mini	64			69			57			57			64			51		
<b>PN 10</b> EN 1092-1 ISO 7005-1	Nombre de trous Number of bolt holes	28	2x28	2x4	28	2x28	2x4	32	2x28	2x4	32	2x32	2x4	32	2x32	2x4	36	2x36	2x4
	Ø boulonnerie Ø of bolts	M33			M36			M39			M39			M39			M45		
	Longueur mini des tirants Mini length of thru-bolts	420	170	155	430	185	175	440	190	155	440	190	155	445	195	170	455	215	165
	A mini	64			69			57			57			64			51		
<b>PN 16</b> EN 1092-1 ISO 7005-1	Nombre de trous Number of bolt holes	28	2x28	2x4	28	2x28	2x4	32	2x32	2x4	32	2x32	2x4	32	2x32	2x4	36	2x36	2x4
	Ø boulonnerie Ø of bolts	M39			M45			M45			M45			M52			M52		
	Longueur mini des tirants Mini length of thru-bolts	455	195	175	470	215	195	480	215	175	480	215	175	495	235	190	500	245	185
	A mini	64			69			57			57			59			51		
<b>PN 20</b> ISO 7005-1	Nombre de trous Number of bolt holes	36	2x36	2x4	40	2x40	2x4							48	2x48	2x4			
	Ø boulonnerie Ø of bolts	M39			M39									M45					
	Longueur mini des tirants Mini length of thru-bolts	550	240	220	560	255	225							620	290	245			
	A mini	64			54									52					
<b>PN 25</b> EN 1092-1 ISO 7005-1	Nombre de trous Number of bolt holes	28		2x4	28		2x4							32		2x4			
	Ø boulonnerie Ø of bolts	M52			M52									M56					
	Longueur mini des tirants Mini length of thru-bolts	500		200	510		215							535		210			
	A mini	64			69									59					
<b>Class 125</b> B16.1 <b>Class 150</b> B16.47-A MSS SP-44 AWWA C207	Nombre de trous Number of bolt holes	36	2x36	2x4	40	2x40	2x4							48	2x48	2x4			
	Ø boulonnerie Ø of bolts	1"1/2-6 UNC (standard) 1"1/2-8 UN (on request)			1"1/2-6 UNC (standard) 1"1/2-8 UN (on request)									1"3/4-5 UNC (standard) 1"3/4-8 UN (on request)					
	Longueur mini des tirants Mini length of thru-bolts	550	240	220	560	255	225							620	290	245			
	A mini	64			54									52					

Rev / Date	A	01/17	B	09/23	C	10/23	D	05/26											
													<b>ROBINET A PAPILLON</b> <b>BUTTERFLY VALVE</b>				159789    13/19 JANVIER 2017		

# Heavy duty resilient seated butterfly

DN 1050 / DN 1600

NPS 42 / NPS 64

## 10.1 DOUBLE BRIDE / DOUBLE FLANGE : Compatibilité de raccordement / Flange drilling compatibility

	DN	1050	1100	1200	1300	1350	1400	1500	1600
	NPS	42	44	48	52	54	56	60	64
<b>ISO 7005 EN 1090</b>	PN 6							(1)	(1)
	PN 10								
	PN 16								
	PN 20						(1)		
	PN 25			(1)			(1)		
<b>ASME B16.1</b>	Class 125								
<b>ASME B16.47 Serie A</b>	Class 150						(1)		
<b>MSS SP-44</b>							(1)		
<b>API 605</b>							(1)	(1)	
<b>AWWA C207</b>	Tables 2-3-4-5								
<b>ASME B16.47 Serie A</b>	Class 300			(1)			(1)	(1)	
<b>MSS SP-44</b>				(1)			(1)	(1)	
<b>API 605</b>				(1)					
<b>BS 10</b>	Table A							(1)	
	Table D							(1)	
	Table E								
<b>JIS B 2210</b>	5K			(1)				(1)	
	10K							(1)	
	16K			(1)					

	Raccordement possible	<i>Flange drilling possible</i>
	Raccordement impossible	<i>Flange drilling impossible</i>
	Raccordement non défini par la norme	<i>Flange drilling not defined by standard</i>
(1)	Consulter le département technique	<i>Consult the technical department</i>

## 10.2 Couple de serrage / Tightening torque

M12		26 N.m	M30	1"1/8	430 N.m
M16	5/8"	63 N.m	M33	1"1/4	580 N.m
M20	3/4"	120 N.m	M36		750 N.m
M22		170 N.m	M39	1"1/2	970 N.m
M24	7/8"	210 N.m	M45	1"3/4	1500 N.m
M27	1"	310 N.m	M52	2"	2330 N.m
			M56		2870 N.m

Rev / Date	A	01/17	B	09/23	C	10/23	D	05/26							
											<b>ROBINET A PAPILLON</b> <b>BUTTERFLY VALVE</b>			159789	14/19
<b>JANVIER 2017</b>															

## 11. INSTALLATION / ASSEMBLY

### 11.1 Vitesse fluide / Fluid speed

Les robinets papillons sont conçus pour une vitesse d'écoulement maximale préconisée :

Butterfly valves are designed for a maximum recommended flow speed:

Pression de service	Vitesse d'écoulement préconisée / Max flow speed recommended	
Working pressure	Fluide liquide / Liquid	Fluide gazeux / Gas
PS < 6 bar	2,5 m/s	25 m/s
PS < 10 bar	3 m/s	30 m/s
PS < 16 bar	4 m/s	35 m/s
PS < 25 bar	5 m/s	40 m/s

Conformément aux normes / Conform to standards : EN 593 & EN 1074

### 11.2 Installation / Assembly

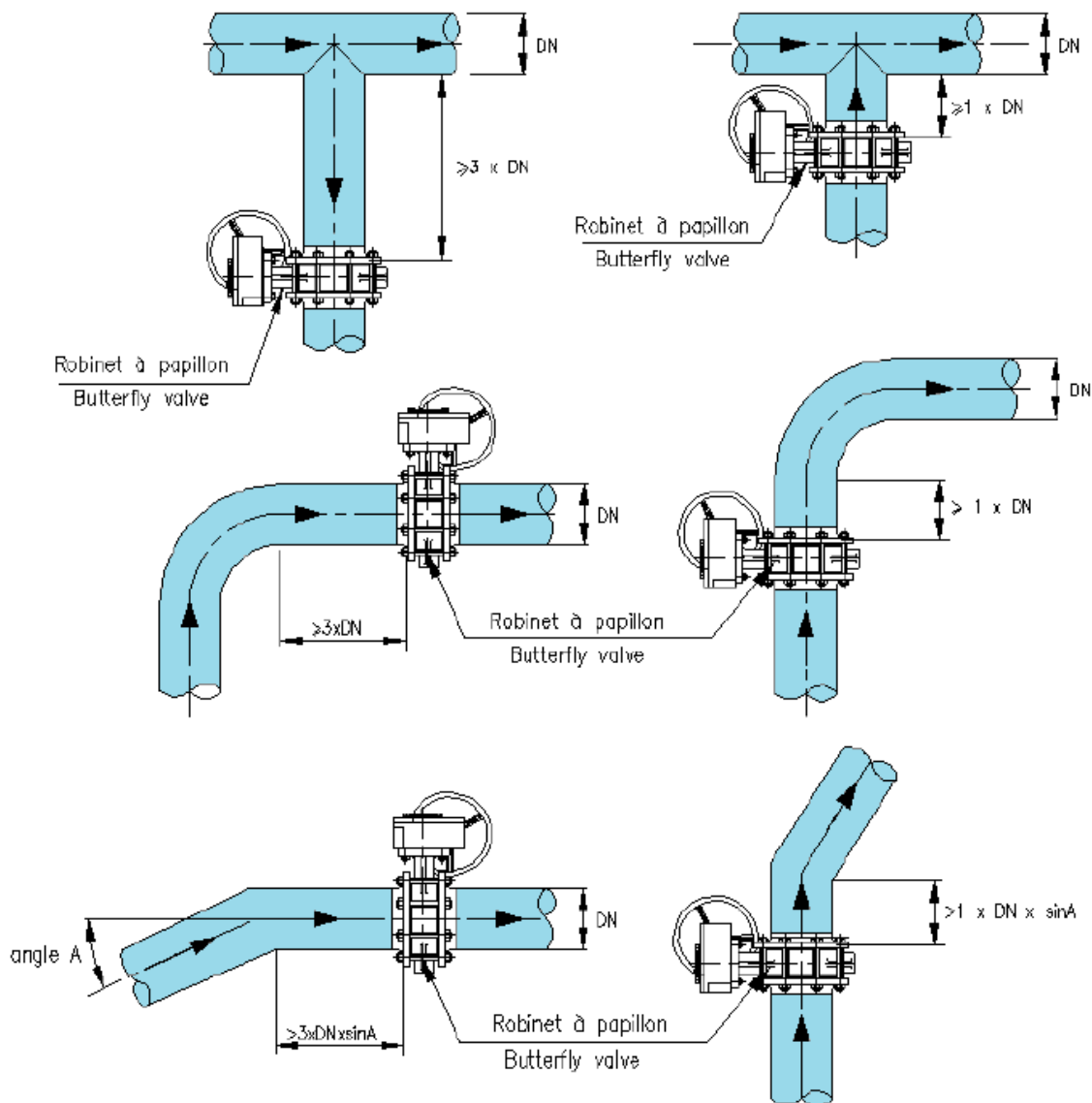

Rev / Date	A	01/17	B	09/23	C	10/23	D	05/26							
											<p align="center"><b>ROBINET A PAPILLON</b> <b>BUTTERFLY VALVE</b></p>			159789	15/19
														JANVIER 2017	

### 11.3 Orientation ligne d'arbre / Shaft orientation

DN1050 – DN2400  
NPS42”–NPS96”

Arbre horizontal  
*horizontal shaft*

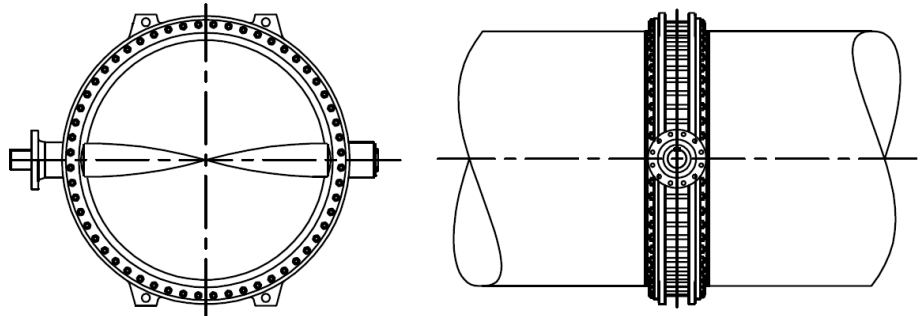

### 11.4 Instruction de montage / Assembly instruction

Bride 12 trous



1 - Centrer le robinet à l'aide de la visserie. Serrer progressivement les tirants diamétralement opposés par alternance jusqu'à obtenir le serrage métallique du corps du robinet sur les faces de brides.

1 - Center the valve with the bolting. Progressively tighten bolts by alternating sides until you have contact between valve and flange faces.

2 - Contrôle après montage : effectuer une ouverture et une fermeture complète du papillon pour s'assurer que rien ne s'oppose à son débattement.

2 - Control: operate valve from fully opened position to fully closed position to make nothing obstruct the disc.

Rev / Date	A	01/17	B	09/23	C	10/23	D	05/26								
											<b>ROBINET A PAPILLON</b> <b>BUTTERFLY VALVE</b>			159789	16/19	JANVIER 2017

### 11.5 Cotes des brides / Flanges dimensions

Cotes données pour un robinet parfaitement centré.

Brides à face surélevée : montage impossible avec brides PN 6

Les brides type 11 sont recommandées pour les pressions de service supérieure à 16 bar.

*Dimensions for valve perfectly centered*

*Flanges with raised face: impossible mounting with PN 6 flanges*

*Type 11 flanges are recommended for working pressure above 16 bar.*

DN	ØD mini	ØD maxi
1050	1008	1068
1100	1079	1120
1200	1179	1221
1300	1281	1323
1350	1339	1390
1400	1393	1424
1500	1494	1526
1600	1596	1628

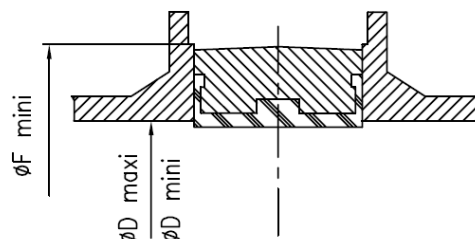

Lors d'un montage avec une tuyauterie de diamètre inférieure à celui de la vanne, un chanfrein sur la bride peut être requis.

*When mounting with piping of smaller diameter than the valve, a chamfer on the flange may be required.*

DN	ØA	α
1050	1008	15°
1100	1079	13°
1200	1179	12°
1300	1281	10°
1350	1339	10°
1400	1393	10°
1500	1494	10°
1600	1596	9°

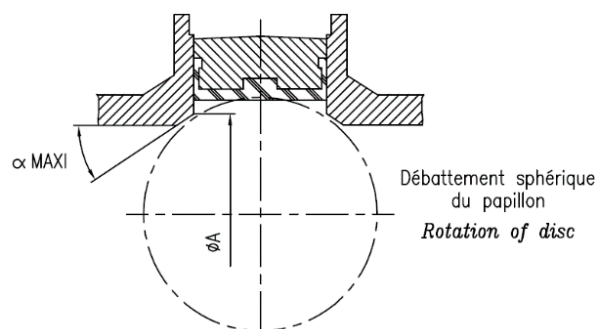

Rev / Date	A	01/17	B	09/23	C	10/23	D	05/26							
												<b>ROBINET A PAPILLON</b> <b>BUTTERFLY VALVE</b>		159789	17/19
												<b>JANVIER 2017</b>			

### 11.6 Montage en bout de conduite / Mounting a valve in a dead end service.

Le montage en bout de conduit est autorisé uniquement pour les vannes classées au plus **Cat.1** (gaz ou liquide classé groupe II (non dangereux)) suivant les règles établies par la Directive Européennes des Equipements sous pression, et des installations sans régime de pression pulsatoire.

Le montage du robinet doit être effectué dans les règles de l'art ; Visserie en bon état sans oxydation.

*Installation at the end of the pipe is authorized only for valves classified **Cat.1 or less** (gas or liquid classified Group II (non dangerous)) in accordance with the rules laid down by the European Pressure Equipment Directive, and on installation without pulsating conditions.*

*The valve shall be installed according to traditional rules; bolting shall be in good condition (no oxydation).*

**ATTENTION :**

Pour des raisons de sécurité, le robinet à papillon utilisé dans ces conditions de montage, en bout de conduite, assure uniquement une fonction de bride pleine.

En position fermé l'organe de manœuvre doit être **verrouillé** afin d'éviter toute manœuvre non autorisée.

L'ouverture du robinet n'est possible qu'après avoir pris toutes les mesures de sécurité.

La pression maximale d'utilisation de la vanne en bout de conduite *PS(BdC)* sera, compte tenu de la pression de service *PS* de la vanne en conduite limité à :

**WARNING:**

For safety reasons, the butterfly valve used in these mounting conditions (dead end service) only serves as a blind flange function.

In the closed position the actuator must be **locked** in order to prevent unauthorized maneuvering.

Valves can be operated again only after taking all safety precautions.

The maximum operating pressure of the valve at the end of the pipe *PS(BdC)* will be, taking into account the working pressure *PS* of the valve in driving limited to:

$$PS(BdC) = PS \times 0.733$$

PS / WP (bar)	PS(BdC) (bar)
6	4,4
10	7,3
16	11,7
20	14,6
25	18,3

Rev / Date	A	01/17	B	09/23	C	10/23	D	05/26							
												<b>ROBINET A PAPILLON</b> <b>BUTTERFLY VALVE</b>		159789	18/19
														JANVIER 2017	

## 12. Démontage ou montage tuyauterie amont ou aval / Dismantling - mounting pipe

AVERTISSEMENTS :	WARNING:
A - Ces instructions sont applicables aux vannes type <b>WAFER</b> pour les tirants traversant les oreilles. Les autres tirants seront démontés <b>après</b> application du 1.1 ou du 1.2, et remontés <b>avant</b> application du 2.1 ou du 2.2.	A - These instructions are applicable to <b>WAFER</b> type valves for tie rods through the ears. The other tie-rods will be dismantled <b>after</b> application of 1.1 or 1.2 and rebuilt <b>before</b> application of 2.1 or 2.2.
B – Vérifier que les tuyauteries amont et aval sont à la pression atmosphérique.	B - Check that the upstream and downstream piping are at atmospheric pressure
C – Vérifier que le robinet est en position fermé	C - Check that the valve is in the closed position
D - Vérifier que la tuyauterie à démonter a été vidangée ou que les dispositions adéquates compte tenu de la réglementation locale ont été prises afin d'assurer l'évacuation du fluide résiduel en toute sécurité.	D - Verify that the piping to be disassembled has been drained or that proper arrangements have been made in accordance with local regulations to ensure safe disposal of the waste fluid.
E – Vérifier que les éléments de tuyauterie sont soutenus ou suspendus de manière sûre.	E - Check that the piping elements are securely supported or suspended.

## 13. Conditions de stockage / Storage conditions

Il conviendra de prendre toutes les précautions d'usage lors de la manutention et du stockage des équipements à savoir :

- Stockage à l'intérieur des bâtiments (température  $\geq 6^{\circ}$ ) sous l'emballage d'origine.
- Les opérations de manutention à des températures inférieures devront être entreprises occasionnellement en évitant expressément les chocs et les contraintes sur le matériel. De préférence, procéder à ces manutentions sous emballage.
- Veiller lors du déballage à ne pas endommager les portées de joints. Manipuler les appareils avec précaution.
- Les vannes comportant des élastomères doivent être entreposées à l'abri de la lumière et de la chaleur.

It will be necessary to take all the precautions of use during the handling and the storage of the equipment namely:

- Storage inside buildings (temperature  $\geq 6^{\circ}$ ) under the original packaging.
- Handling operations at lower temperatures should be carried out occasionally, specifically avoiding shocks and stresses on the equipment. Preferably, carry out these handling operations under packaging.
- When unpacking, do not damage the sealing surfaces. Handle devices with care.
- Valves with elastomers must be stored away from light and heat.

Rev / Date	A	01/17	B	09/23	C	10/23	D	05/26									
												<b>ROBINET A PAPILLON</b> <b>BUTTERFLY VALVE</b>			159789	19/19	JANVIER 2017